

Please check the examination details below before entering your candidate information

Candidate surname					Other names				
Centre Number				Candidate Number					
<input type="text"/>	<input type="text"/>	<input type="text"/>	<input type="text"/>	<input type="text"/>	<input type="text"/>	<input type="text"/>	<input type="text"/>	<input type="text"/>	<input type="text"/>
Pearson Edexcel International Advanced Level									
Wednesday 11 October 2023									
Morning (Time: 1 hour 30 minutes)					Paper reference		WPH11/01		
Physics									
International Advanced Subsidiary/Advanced Level									
UNIT 1: Mechanics and Materials									
You must have: Scientific calculator, ruler, protractor								Total Marks	

Instructions

- Use **black** ink or ball-point pen.
- If pencil is used for diagrams/sketches/graphs it must be dark (HB or B).
- **Fill in the boxes** at the top of this page with your name, centre number and candidate number.
- Answer **all** questions.
- Answer the questions in the spaces provided
– *there may be more space than you need.*
- **Show all your working out** in calculations and **include units** where appropriate.

Information

- The total mark for this paper is 80.
- The marks for **each** question are shown in brackets
– *use this as a guide as to how much time to spend on each question.*
- In the question marked with an **asterisk** (*), marks will be awarded for your ability to structure your answer logically, showing how the points that you make are related or follow on from each other where appropriate.
- The list of data, formulae and relationships is printed at the end of this booklet.

Advice

- Read each question carefully before you start to answer it.
- Try to answer every question.
- Check your answers if you have time at the end.

Turn over ►

P75621A

©2023 Pearson Education Ltd.
Z:1/1/1/



Pearson

SECTION A

Answer ALL questions.

For questions 1–10, in Section A, select one answer from A to D and put a cross in the box ☒. If you change your mind, put a line through the box ☒ and then mark your new answer with a cross ☒.

1 A quantity is either a scalar or a vector.

Which row of the table is correct?

	Scalar	Vector
<input type="checkbox"/> A	energy	momentum
<input type="checkbox"/> B	displacement	acceleration
<input type="checkbox"/> C	time	mass
<input type="checkbox"/> D	velocity	force

(Total for Question 1 = 1 mark)

2 Which of the following is an SI unit for momentum?

- A kg m s^{-1}
- B J m^{-1}
- C m s^{-2}
- D N s^{-1}

(Total for Question 2 = 1 mark)

3 Which of the following could be used to describe the elastic limit of a material?

- A The stress above which the material will not obey Hooke's law.
- B The stress above which the material will be deformed when the stress is removed.
- C The stress at which the material undergoes a sudden increase in extension.
- D The stress at which the material breaks.

(Total for Question 3 = 1 mark)

DO NOT WRITE IN THIS AREA

DO NOT WRITE IN THIS AREA

DO NOT WRITE IN THIS AREA



4 A ball falls through air from rest.

Which of the following shows the graph of displacement against time for the ball?

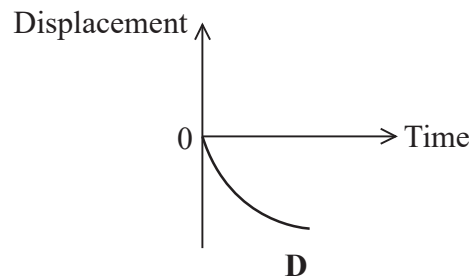
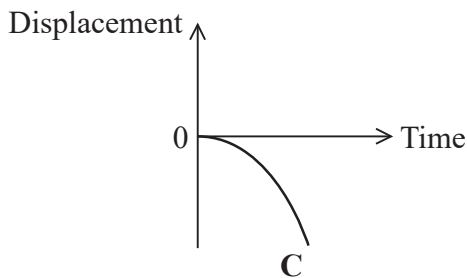
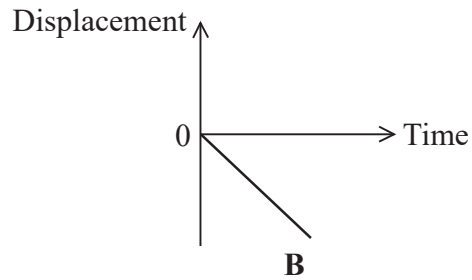
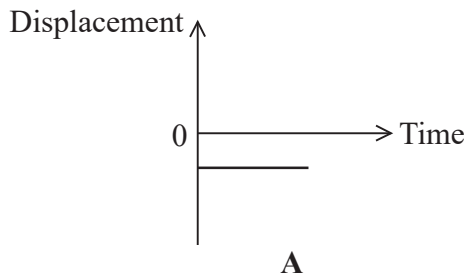

- A
- B
- C
- D

(Total for Question 4 = 1 mark)

5 A helicopter moves vertically upwards with an increasing speed.

Which of the following describes the increase in gravitational potential energy of the helicopter?

- A The work done on the helicopter by the force of gravity.
- B The total work done by the helicopter as it moves upwards.
- C The work done by the helicopter against the force of gravity.
- D The work done by the helicopter to increase speed.

(Total for Question 5 = 1 mark)

- 6 An object moves with a velocity v .

The kinetic energy of the object is doubled.

Which of the following is an expression for the new velocity of the object?

- A $\sqrt{2}v$
- B $2v$
- C $2\sqrt{2}v$
- D $4v$

(Total for Question 6 = 1 mark)

- 7 A power station provides an electrical output power of 2.1 GW. The power station transfers thermal energy to the surroundings at a rate of 3.4 GW.

Which of the following gives the efficiency of the power station?

- A $\frac{2.1}{3.4 + 2.1}$
- B $\frac{3.4}{3.4 + 2.1}$
- C $\frac{3.4 - 2.1}{2.1}$
- D $\frac{3.4 - 2.1}{3.4}$

(Total for Question 7 = 1 mark)

- 8 A student applied a tensile force to a metal wire of length x and diameter d .

The length of the wire increased by Δx .

The student applied the same force to a second wire made of the same material.

The length of the second wire increased by $2\Delta x$.

Which row of the table could show the length and diameter of the second wire?

- | | Length | Diameter |
|----------------------------|--------|----------|
| <input type="checkbox"/> A | $0.5x$ | $0.5d$ |
| <input type="checkbox"/> B | $0.5x$ | $2d$ |
| <input type="checkbox"/> C | $2x$ | $0.5d$ |
| <input type="checkbox"/> D | $2x$ | $2d$ |

(Total for Question 8 = 1 mark)



9 A box of weight W is suspended, in equilibrium, from a support by two ropes.

The tensions in the two ropes are T_1 and T_2

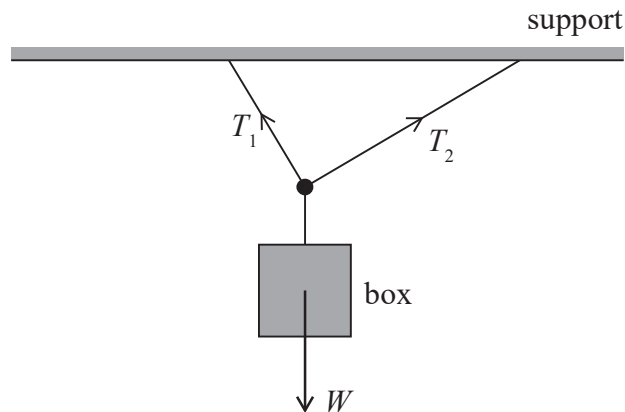

Which of the following is a vector expression relating the forces acting on the box?

- A $\vec{W} + \vec{T}_1 = \vec{T}_2$
- B $\vec{W} + \vec{T}_2 = \vec{T}_1$
- C $\vec{W} = \vec{T}_1 + \vec{T}_2$
- D $\vec{W} + \vec{T}_1 + \vec{T}_2 = \mathbf{0}$

(Total for Question 9 = 1 mark)

10 A box is pulled along the ground by a rope inclined at an angle of 40° to the horizontal as shown.

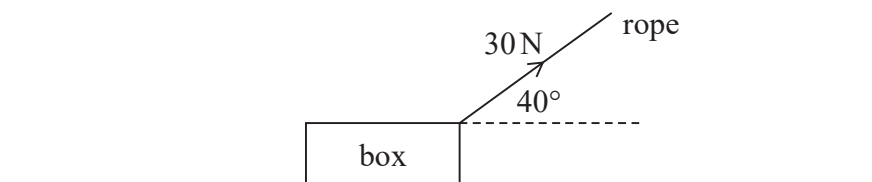

The tension in the rope is 30 N.

The box is pulled 5 m along the ground.

Which of the following is the work done on the box?

- A 150 J
- B 115 J
- C 96 J
- D 23 J

(Total for Question 10 = 1 mark)

TOTAL FOR SECTION A = 10 MARKS

SECTION B

Answer ALL questions in the spaces provided.

11 The photograph shows a rocket. This rocket is launched vertically.



(Source: <https://www.nasa.gov/image-feature/the-spacex-falcon-9-rocket-in-vertical-position-on-the-launch-pad>)

(a) The rocket's engines give a total upward thrust of $7.3 \times 10^7 \text{ N}$.

Calculate the initial acceleration of the rocket.

mass of rocket = $5.0 \times 10^6 \text{ kg}$

(3)

.....
.....
.....
.....
.....
.....

Initial acceleration =

(b) Give one reason why the acceleration will increase as the rocket rises.

(1)

.....
.....

(Total for Question 11 = 4 marks)

DO NOT WRITE IN THIS AREA

DO NOT WRITE IN THIS AREA

DO NOT WRITE IN THIS AREA



12 A teacher demonstrated the principle of conservation of linear momentum using two gliders, A and B, and an air track. A has the same mass as B.

A and B were initially stationary, then A was pushed gently towards B as shown.

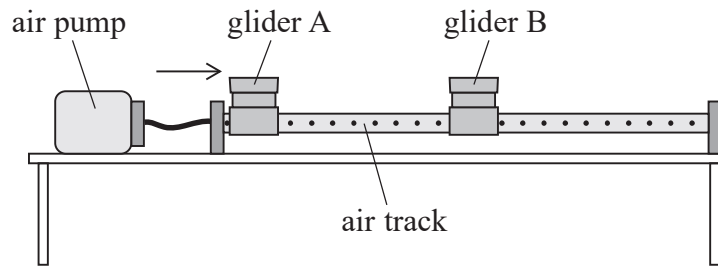

(a) State the principle of conservation of linear momentum.

(2)

.....

.....

(b) A magnet was attached to each glider. The gliders collided and stuck together.

A data logger and sensor were used to record the velocity of A. The velocity recorded after the collision was half the velocity recorded before the collision.

(i) Deduce whether these results show that the law of conservation of linear momentum is obeyed.

(2)

.....

.....

.....

(ii) Explain why the force of attraction between the two magnets did not affect this demonstration.

(2)

.....

.....

.....

(Total for Question 12 = 6 marks)

13 Tennis players can practise using a tennis ball machine. The machine projects tennis balls horizontally from a height of 2.54 m, as shown.

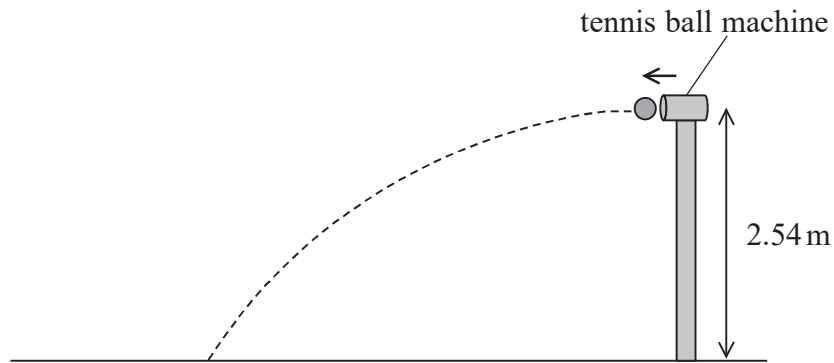

(a) (i) Show that the time taken for a ball to reach the ground is about 0.7 s.

(2)

.....

.....

.....

.....

(ii) The ball lands on the ground at a horizontal distance of 17.89 m from the machine.

Calculate the velocity of the ball as it is projected from the machine.

(2)

.....

.....

.....

Velocity =

DO NOT WRITE IN THIS AREA

DO NOT WRITE IN THIS AREA

DO NOT WRITE IN THIS AREA



- 14 A student exercises by lifting weights attached to a machine. The machine has a cable, as shown in the photograph. The cable passes through a handle and is connected to a weight.

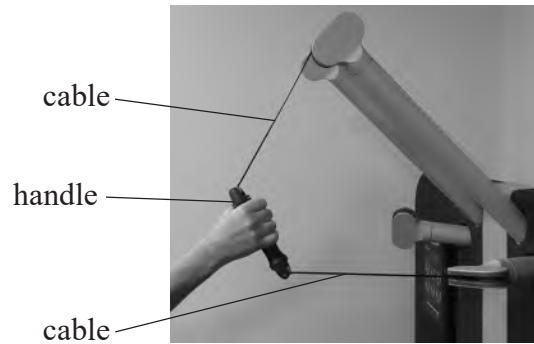

There is a tension T in the cable. The angle between the two sides of the cable is 60° as shown in the diagram.

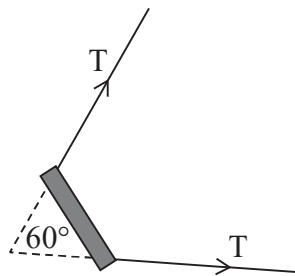

Not to scale

- (a) A person keeps the cable stationary by applying a force F of 121 N.

Determine the magnitude of the tension T in the cable using a scaled vector diagram.

(4)

$T = \dots\dots\dots$

DO NOT WRITE IN THIS AREA

DO NOT WRITE IN THIS AREA

DO NOT WRITE IN THIS AREA



DO NOT WRITE IN THIS AREA

DO NOT WRITE IN THIS AREA

DO NOT WRITE IN THIS AREA

BLANK PAGE



DO NOT WRITE IN THIS AREA

DO NOT WRITE IN THIS AREA

DO NOT WRITE IN THIS AREA

15 The photograph shows a ladder that a person can use to climb into the roof space of a building.

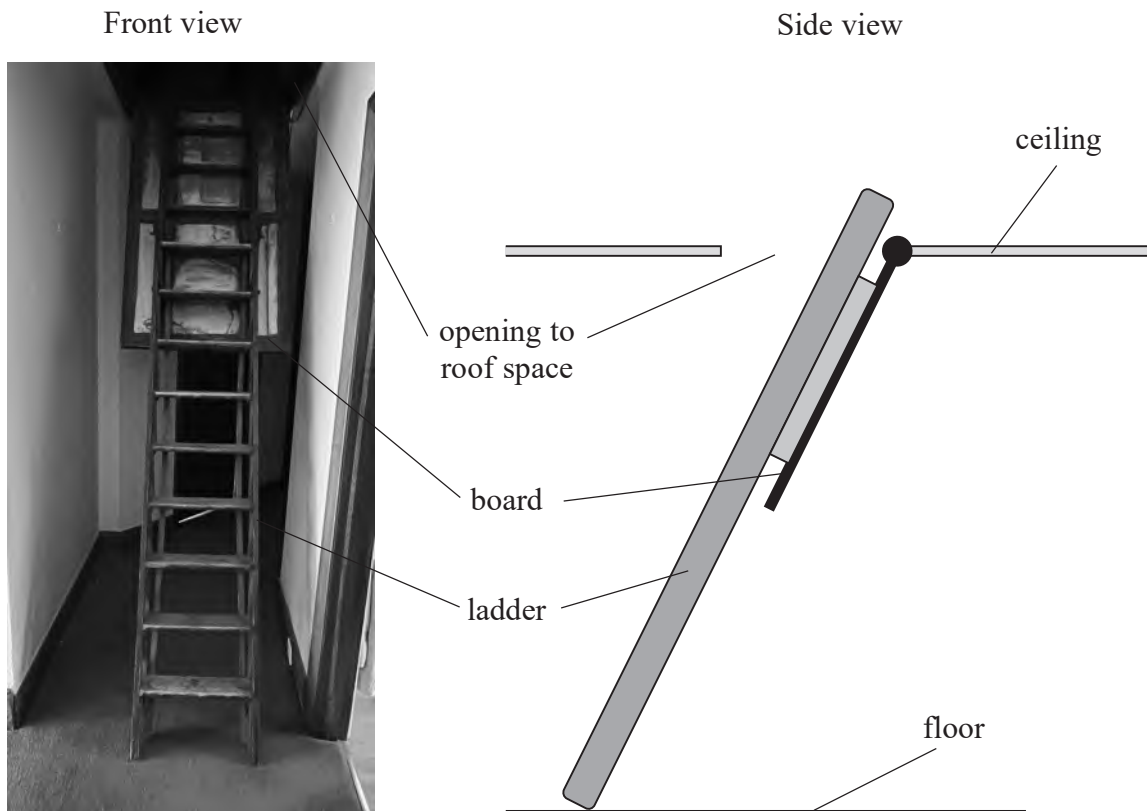

When not in use, the ladder is stored in the roof space and the opening to the roof space is covered by a board. The board is hinged to the ceiling at one end.

The ladder is attached to the board by a rail, as shown below. A small block prevents the board from rotating into the roof space.

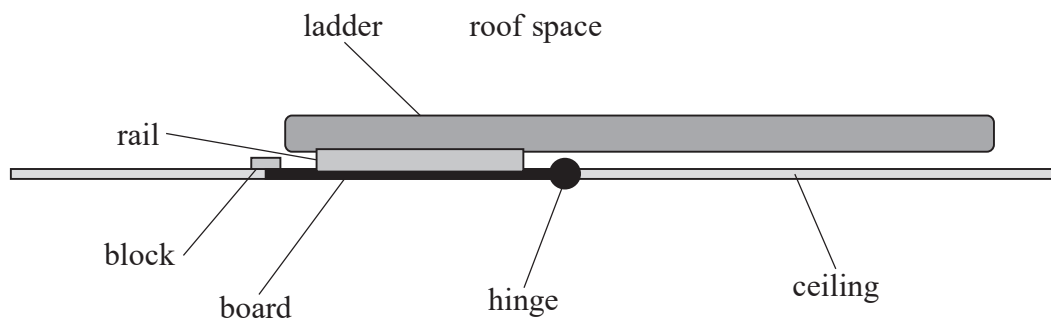

(a) State what is meant by the centre of gravity of an object.

(1)

.....

.....



- (b) The weight of the board and rail is 50 N. The weight acts at a distance of 0.45 m from the hinge as shown.

The total length of the ladder is 2.70 m, with 0.85 m to the left of the hinge.

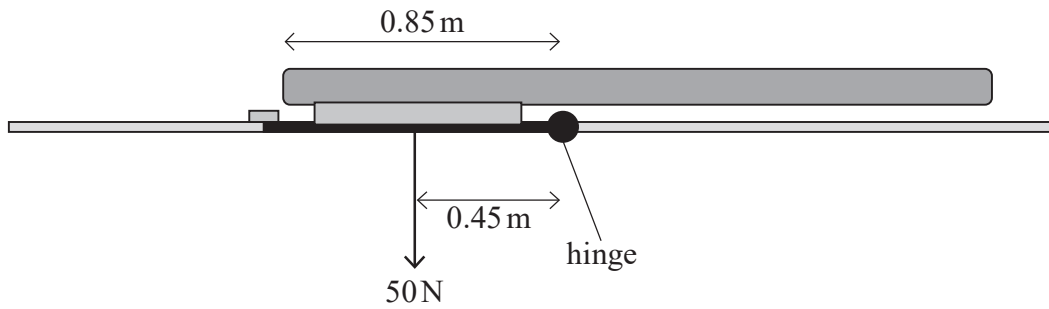

The weight of the ladder is 54 N. Assume the ladder is uniform.

- (i) Explain why the board and ladder remain in the position shown.

(5)

.....

.....

.....

.....

.....

.....

.....

.....

.....

.....

DO NOT WRITE IN THIS AREA

DO NOT WRITE IN THIS AREA

DO NOT WRITE IN THIS AREA



(ii) A downward force is required to rotate the board away from the block. This force is applied 0.80 m from the hinge.

Determine the magnitude of this force.

(2)

.....

.....

.....

.....

Magnitude of force =

(Total for Question 15 = 8 marks)

DO NOT WRITE IN THIS AREA

DO NOT WRITE IN THIS AREA

DO NOT WRITE IN THIS AREA



P 7 5 6 2 1 A 0 1 5 2 4

16 A steel object is held by an electromagnet. The magnetic force prevents the steel object falling.

- (a) State **two** reasons why the weight of the object and the force from the electromagnet are not a Newton third law pair.

(2)

.....

.....

.....

- (b) The electromagnet is suspended from a support by a steel cable, as shown.

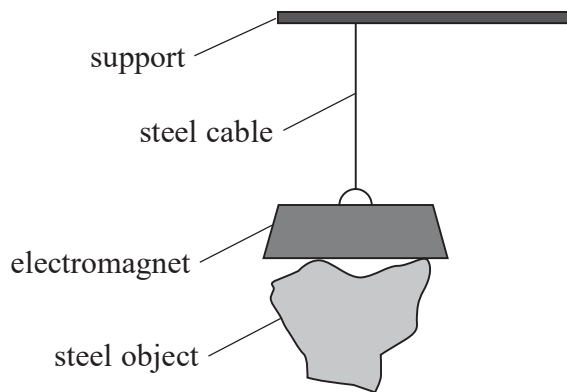

- (i) When the object is suspended, the strain in the cable is 3.0×10^{-4}

Calculate the Young modulus of the steel in the cable.

cross-sectional area of cable = $5.1 \times 10^{-4} \text{ m}^2$

unstretched length of cable = 3.8 m

stiffness of cable = $2.8 \times 10^7 \text{ N m}^{-1}$

(4)

.....

.....

.....

.....

.....

.....

.....

Young modulus =



DO NOT WRITE IN THIS AREA

DO NOT WRITE IN THIS AREA

DO NOT WRITE IN THIS AREA

- 17 Scientists use weather balloons to carry equipment into the upper atmosphere to monitor weather conditions. The photograph shows a weather balloon.

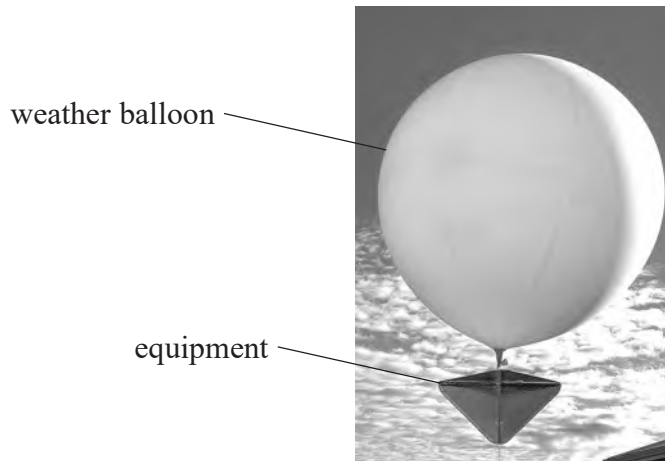

(Source: © Edward Haylan/Shutterstock)

Upthrust acts on the balloon. The balloon is released and accelerates upwards.

- (a) State what is meant by upthrust.

(1)

.....

.....

- (b) (i) When the balloon is released, the initial upward acceleration is 4.80 ms^{-2} .

Show that the weight of the balloon and equipment is about 13 N.

volume of balloon and equipment = 1.63 m^3

density of air at ground level = 1.23 kg m^{-3}

(3)

.....

.....

.....

.....

.....

.....

.....



(ii) The graph shows how the density of air decreases with height above the ground.

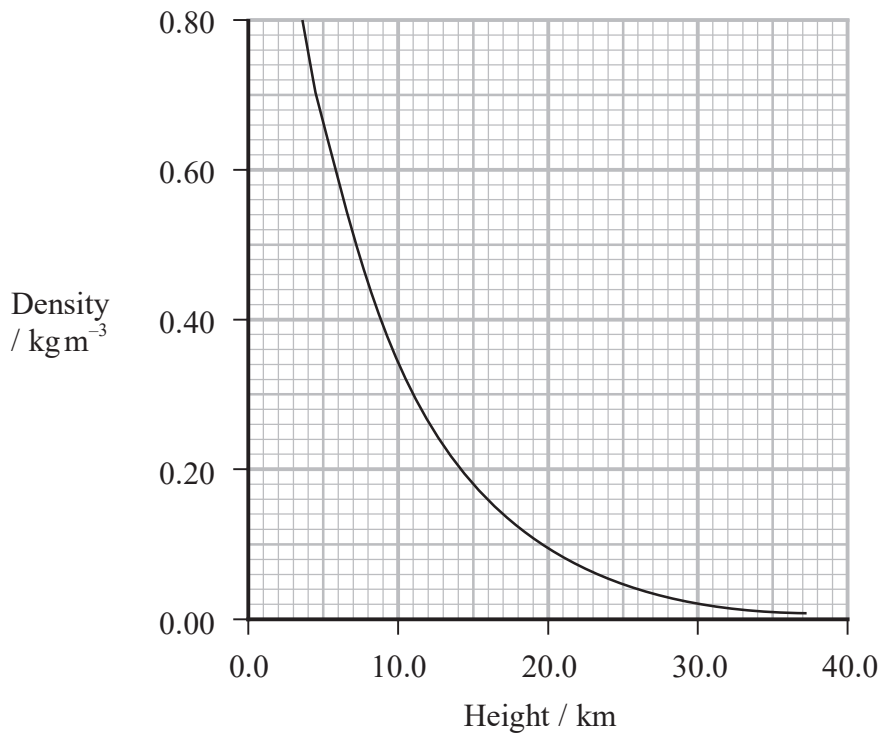

The scientists want to make measurements at a height of 25 km where the balloon would stop rising.

The balloon will expand as it rises and will burst if its volume exceeds 50 m³.

Deduce whether the weather balloon could support the equipment at a height of 25 km, without bursting.

(4)

.....

.....

.....

.....

.....

.....

.....

.....

.....

DO NOT WRITE IN THIS AREA

DO NOT WRITE IN THIS AREA

DO NOT WRITE IN THIS AREA



P 7 5 6 2 1 A 0 1 9 2 4

*(c) A weather balloon made of a strong material will rise and eventually stop expanding. It will continue to rise until it reaches a maximum height.

Explain how and why the velocity of the weather balloon changes from release until it reaches its maximum height.

Ignore the effects of viscous drag force.

(6)

.....

.....

.....

.....

.....

.....

.....

.....

.....

.....

.....

.....

.....

.....

.....

.....

.....

.....

.....

.....

.....

.....

.....

(Total for Question 17 = 14 marks)

DO NOT WRITE IN THIS AREA

DO NOT WRITE IN THIS AREA

DO NOT WRITE IN THIS AREA



DO NOT WRITE IN THIS AREA

DO NOT WRITE IN THIS AREA

DO NOT WRITE IN THIS AREA

BLANK PAGE



P 7 5 6 2 1 A 0 2 1 2 4

18 A student carried out an experiment using a data logger to record the motion of a ball-bearing as it fell through a liquid.

(a) State the conditions under which Stokes' law applies to an object moving through a fluid.

(2)

.....

.....

.....

(b) The graph obtained by the student is shown below.

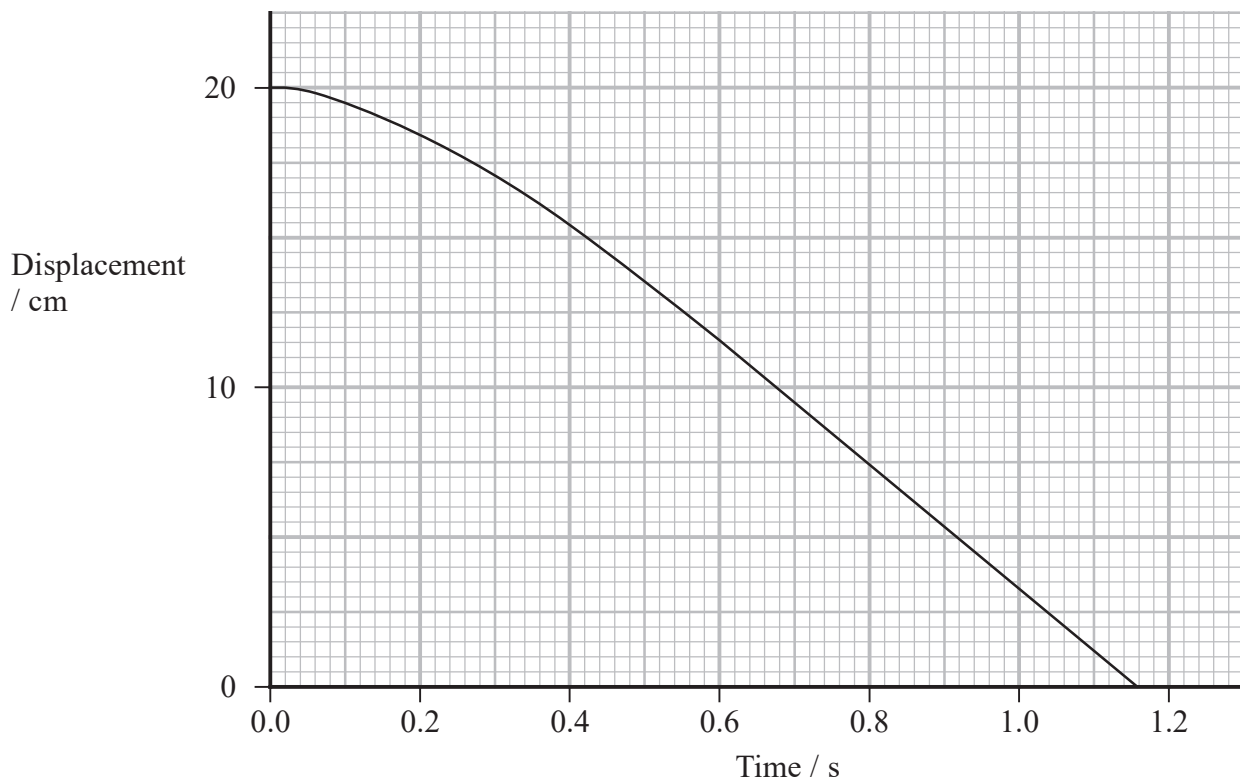

(i) Explain the shape of the graph.

(3)

.....

.....

.....

.....

.....

.....

DO NOT WRITE IN THIS AREA

DO NOT WRITE IN THIS AREA

DO NOT WRITE IN THIS AREA



DO NOT WRITE IN THIS AREA

DO NOT WRITE IN THIS AREA

DO NOT WRITE IN THIS AREA

(ii) The ball-bearing had a diameter of 1.6 mm.

The difference between the upthrust on the ball-bearing and the weight of the ball-bearing is 1.45×10^{-4} N.

Calculate the viscosity of the liquid. Assume that Stokes' law applies.

(4)

.....
.....
.....
.....
.....
.....
.....
.....

Viscosity = Pas

(iii) The student heated the liquid and repeated the experiment.

The ball-bearing took less time to fall a given distance in the liquid when the liquid was at a higher temperature.

Explain why. Assume the density of the liquid is constant.

(4)

.....
.....
.....
.....
.....
.....
.....
.....
.....
.....

(Total for Question 18 = 13 marks)

TOTAL FOR SECTION B = 70 MARKS
TOTAL FOR PAPER = 80 MARKS



List of data, formulae and relationships

Acceleration of free fall $g = 9.81 \text{ m s}^{-2}$ (close to Earth's surface)

Gravitational field strength $g = 9.81 \text{ N kg}^{-1}$ (close to Earth's surface)

Unit 1

Mechanics

Kinematic equations of motion $s = \frac{(u + v)t}{2}$

$$v = u + at$$

$$s = ut + \frac{1}{2}at^2$$

$$v^2 = u^2 + 2as$$

Forces $\Sigma F = ma$

$$g = \frac{F}{m}$$

$$W = mg$$

Momentum $p = mv$

Moment of force moment = Fx

Work and energy $\Delta W = F\Delta s$

$$E_k = \frac{1}{2}mv^2$$

$$\Delta E_{\text{grav}} = mg\Delta h$$

Power $P = \frac{E}{t}$

$$P = \frac{W}{t}$$

Efficiency efficiency = $\frac{\text{useful energy output}}{\text{total energy input}}$

$$\text{efficiency} = \frac{\text{useful power output}}{\text{total power input}}$$

Materials

Density $\rho = \frac{m}{V}$

Stokes' law $F = 6\pi\eta rv$

Hooke's law $\Delta F = k\Delta x$

Elastic strain energy $\Delta E_{\text{el}} = \frac{1}{2}F\Delta x$

Young modulus $E = \frac{\sigma}{\epsilon}$ where

$$\text{Stress } \sigma = \frac{F}{A}$$

$$\text{Strain } \epsilon = \frac{\Delta x}{x}$$

DO NOT WRITE IN THIS AREA

DO NOT WRITE IN THIS AREA

DO NOT WRITE IN THIS AREA

