

Write your name here

|         |             |
|---------|-------------|
| Surname | Other names |
|---------|-------------|

**Pearson Edexcel Certificate**  
**Pearson Edexcel**  
**International GCSE**

Centre Number

|  |  |  |  |  |
|--|--|--|--|--|
|  |  |  |  |  |
|--|--|--|--|--|

Candidate Number

|  |  |  |  |
|--|--|--|--|
|  |  |  |  |
|--|--|--|--|

# Mathematics A

## Paper 3H

**Higher Tier**

Wednesday 14 May 2014 – Morning  
**Time: 2 hours**

Paper Reference  
**4MA0/3H**  
**KMA0/3H**

**You must have:**

Ruler graduated in centimetres and millimetres, protractor, compasses, pen, HB pencil, eraser, calculator. Tracing paper may be used.

Total Marks

|  |
|--|
|  |
|--|

**Instructions**

- Use **black** ink or ball-point pen.
- **Fill in the boxes** at the top of this page with your name, centre number and candidate number.
- Answer **all** questions.
- Without sufficient working, correct answers may be awarded no marks.
- Answer the questions in the spaces provided  
– *there may be more space than you need.*
- **Calculators may be used.**
- You must **NOT** write anything on the formulae page.  
Anything you write on the formulae page will gain **NO** credit.

**Information**

- The total mark for this paper is 100.
- The marks for **each** question are shown in brackets  
– *use this as a guide as to how much time to spend on each question.*

**Advice**

- Read each question carefully before you start to answer it.
- Check your answers if you have time at the end.

Turn over ►

P43028A

©2014 Pearson Education Ltd.

1/1/1/1/



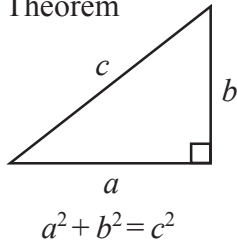

**International GCSE MATHEMATICS  
FORMULAE SHEET – HIGHER TIER**

Pythagoras' Theorem

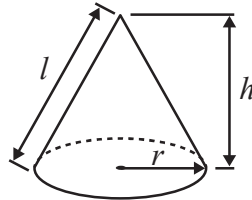

Volume of cone =  $\frac{1}{3} \pi r^2 h$

Curved surface area of cone =  $\pi r l$



Volume of sphere =  $\frac{4}{3} \pi r^3$

Surface area of sphere =  $4\pi r^2$

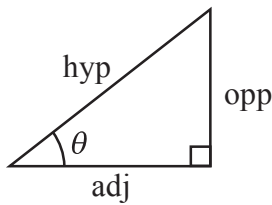
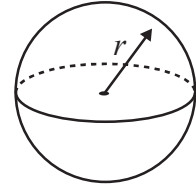

adj = hyp  $\times$  cos  $\theta$   
opp = hyp  $\times$  sin  $\theta$   
opp = adj  $\times$  tan  $\theta$

or  $\sin \theta = \frac{\text{opp}}{\text{hyp}}$

$\cos \theta = \frac{\text{adj}}{\text{hyp}}$

$\tan \theta = \frac{\text{opp}}{\text{adj}}$

In any triangle ABC

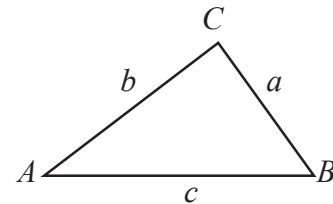

Sine rule:  $\frac{a}{\sin A} = \frac{b}{\sin B} = \frac{c}{\sin C}$

Cosine rule:  $a^2 = b^2 + c^2 - 2bc \cos A$

Area of triangle =  $\frac{1}{2} ab \sin C$

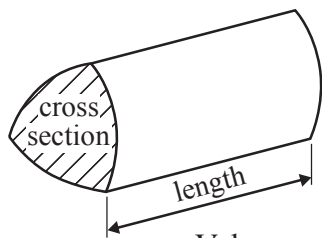

Volume of prism = area of cross section  $\times$  length

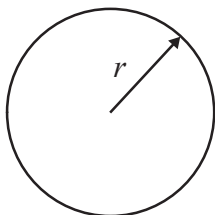

Circumference of circle =  $2\pi r$

Area of circle =  $\pi r^2$

Area of a trapezium =  $\frac{1}{2}(a + b)h$

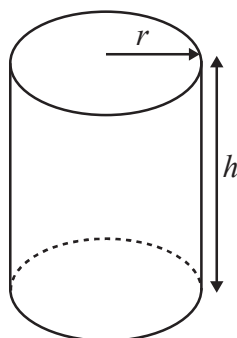
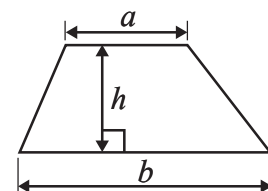

Volume of cylinder =  $\pi r^2 h$

Curved surface area of cylinder =  $2\pi r h$

The Quadratic Equation

The solutions of  $ax^2 + bx + c = 0$ , where  $a \neq 0$ , are given by

$$x = \frac{-b \pm \sqrt{b^2 - 4ac}}{2a}$$



**Answer ALL TWENTY THREE questions.**

**Write your answers in the spaces provided.**

**You must write down all the stages in your working.**

1 (a) Work out the value of  $\frac{13.8 \times 6.5}{7 + \sqrt{2}}$

Write down all the figures on your calculator display.

.....  
(2)

(b) Give your answer to part (a) correct to 3 significant figures.

.....  
(1)

**(Total for Question 1 is 3 marks)**

2 Show that  $\frac{4}{9} \div \frac{5}{6} = \frac{8}{15}$

**(Total for Question 2 is 2 marks)**



3

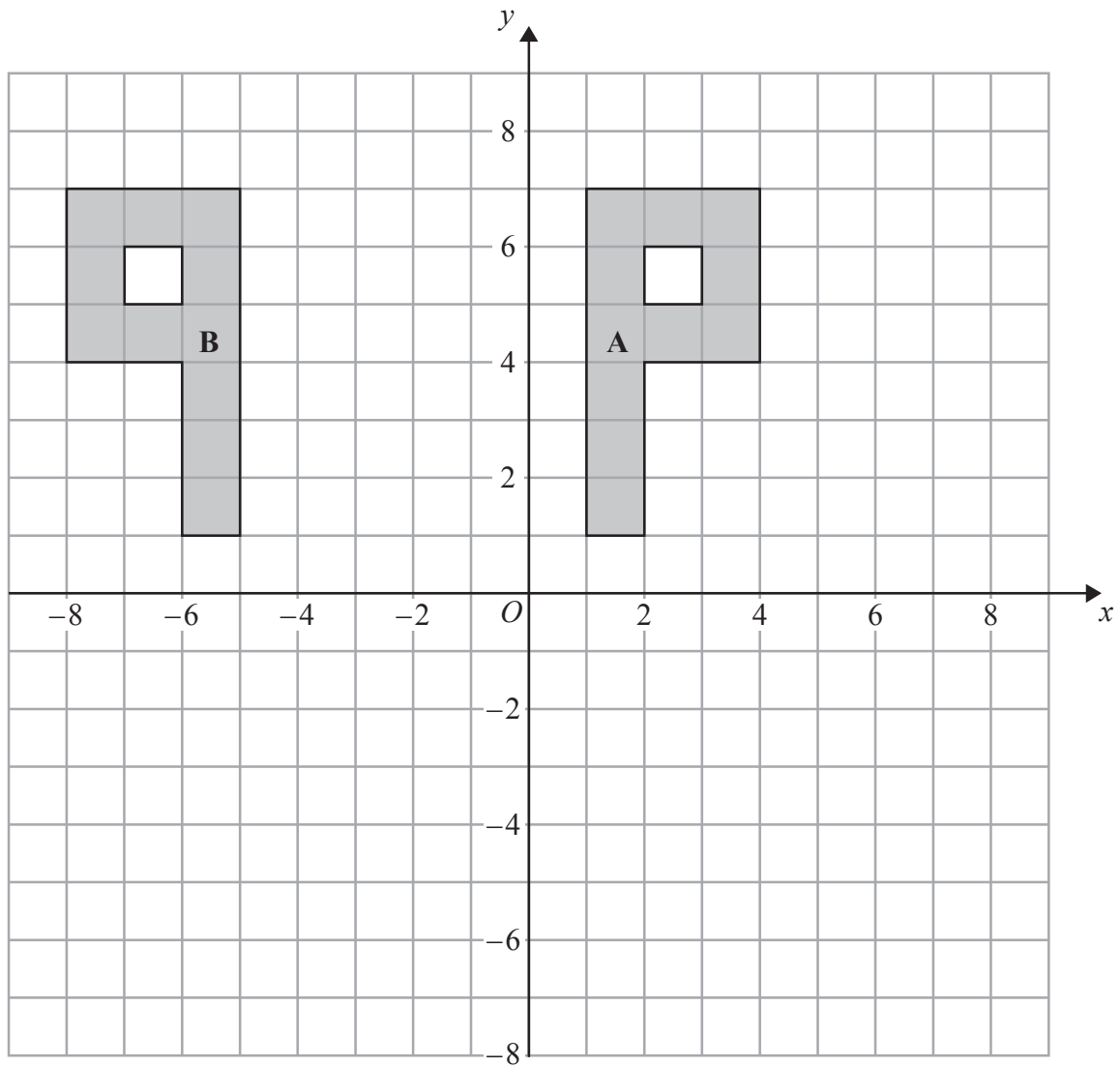

(a) Describe fully the single transformation that maps shape A onto shape B.

(2)

(b) On the grid, rotate shape A  $90^\circ$  clockwise about the origin  $O$ .  
Label the new shape C.

(2)

(Total for Question 3 is 4 marks)

Do NOT write in this space.



4 (a) Simplify  $8d \times 7d$

.....  
(1)

(b) Expand  $4(3e - 5)$

.....  
(1)

(c) Factorise  $f^2 - 2f$

.....  
(2)

(d)  $H = g^3 + 6g$

Work out the value of  $H$  when  $g = 2$

$H =$  .....

(2)

(Total for Question 4 is 6 marks)

5

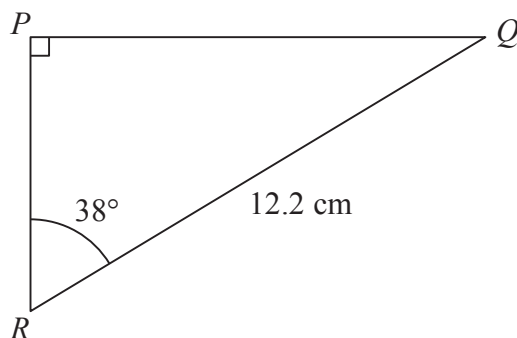

Diagram **NOT**  
accurately drawn

Calculate the length of  $PQ$ .

Give your answer correct to 3 significant figures.

..... cm

(Total for Question 5 is 3 marks)



P 4 3 0 2 8 A 0 5 2 4

- 6 The diagram shows an accurate scale drawing of part of the boundary of a field.  
The complete boundary of the field is in the shape of a quadrilateral  $ABCD$ .

$AB = 300$  metres.

$BC = 230$  metres.

Point  $B$  is due north of point  $C$ .

The scale of the diagram is 1 cm to 50 metres.

The bearing of  $D$  from  $C$  is  $260^\circ$

$AD = 480$  metres.

Complete the scale drawing of the boundary of the field.

Mark the position of  $D$ .

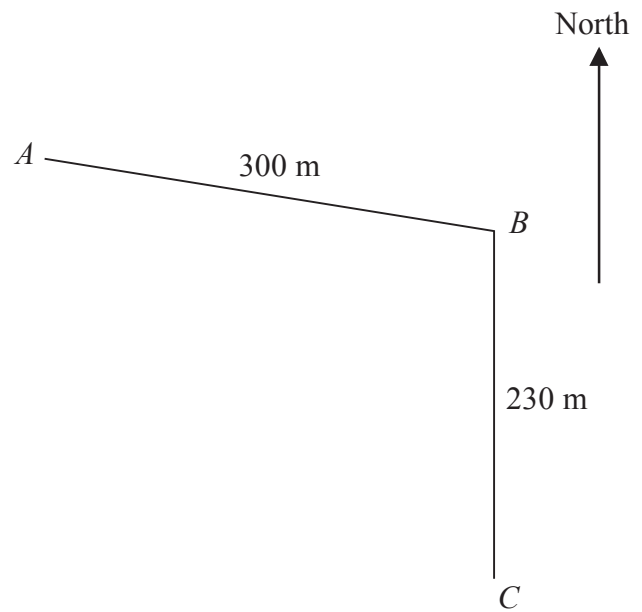

(Total for Question 6 is 2 marks)



7 (a)  $A = \{p, r, a, g, u, e\}$

$B = \{p, a, r, i, s\}$

$C = \{b, u, d, a, p, e, s, t\}$

List the members of the set

(i)  $A \cap B$

.....

(ii)  $B \cup C$

.....

(2)

(b)  $D = \{r, o, m, e\}$

$E = \{l, i, s, b, o, n\}$

$F = \{b, e, r, l, i, n\}$

Put one of the letters  $D$ ,  $E$  or  $F$  in the box below to make the statement correct.

$$A \cap \boxed{\phantom{D}} = \emptyset$$

Explain your answer.

.....  
(1)

(Total for Question 7 is 3 marks)

**Do NOT write in this space.**



- 8 (a) On the grid, draw the line with equation  $x + 2y = 8$  for values of  $x$  from 0 to 9

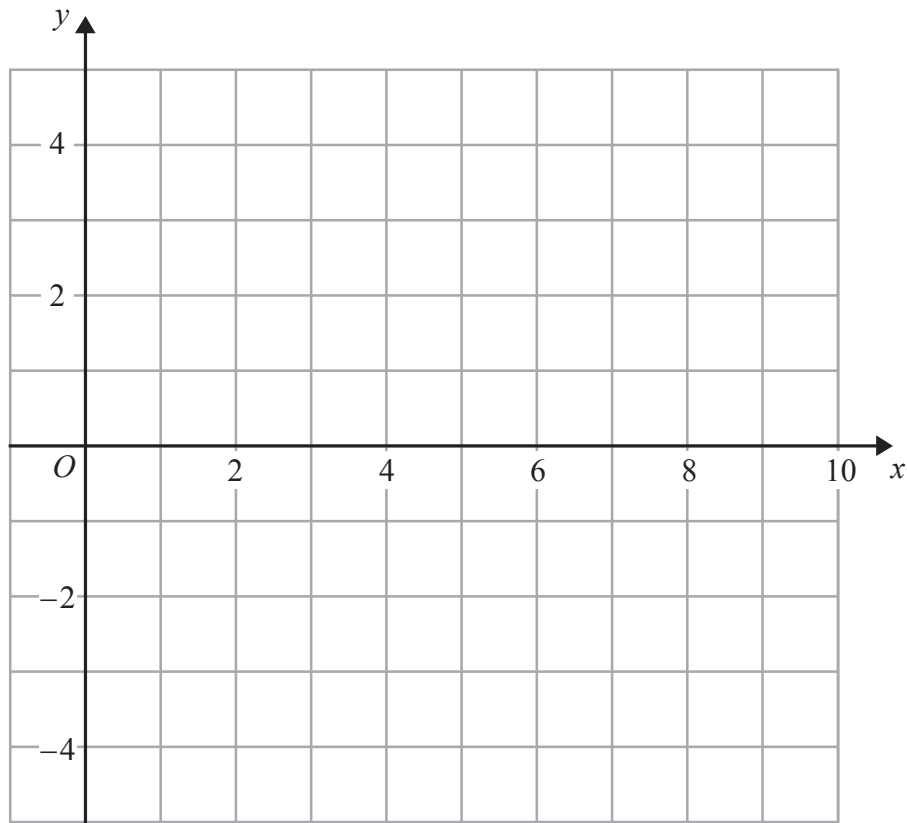

(2)

- (b) Show, by shading on the grid, the region defined by all three inequalities

$$x + 2y \leq 8$$

$$x \geq 2$$

$$y \geq 1$$

Label your region **R**.

(3)

(Total for Question 8 is 5 marks)



9

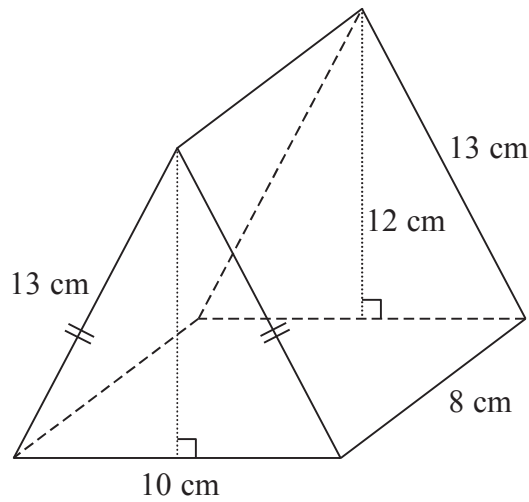

Diagram NOT accurately drawn

The diagram shows a prism.  
 The cross-section of the prism is an isosceles triangle.  
 The lengths of the sides of the triangle are 13 cm, 13 cm and 10 cm.  
 The perpendicular height of the triangle is 12 cm.  
 The length of the prism is 8 cm.

Work out the total surface area of the prism.

..... cm<sup>2</sup>

**(Total for Question 9 is 3 marks)**

**10** Zara must take 5 tests.  
 Each test is out of 100  
 After 4 tests, her mean score is 64%.

What score must Zara get in her 5th test to increase her mean score in all 5 tests to 70%?

.....

**(Total for Question 10 is 4 marks)**



- 11 The table gives information about the speed, in km/h, of 180 vehicles passing a speed checkpoint.

| Speed<br>( $v$ km/h) | Frequency |
|----------------------|-----------|
| $40 < v \leq 50$     | 4         |
| $50 < v \leq 60$     | 52        |
| $60 < v \leq 70$     | 60        |
| $70 < v \leq 80$     | 34        |
| $80 < v \leq 90$     | 18        |
| $90 < v \leq 100$    | 12        |

- (a) Write down the modal class.

.....  
(1)

- (b) Work out an estimate for the probability that the next vehicle passing the speed checkpoint will have a speed of 60 km/h or less.

.....  
(2)

- (c) Complete the cumulative frequency table.

| Speed<br>( $v$ km/h) | Cumulative<br>frequency |
|----------------------|-------------------------|
| $40 < v \leq 50$     |                         |
| $40 < v \leq 60$     |                         |
| $40 < v \leq 70$     |                         |
| $40 < v \leq 80$     |                         |
| $40 < v \leq 90$     |                         |
| $40 < v \leq 100$    |                         |

(1)



(d) On the grid, draw a cumulative frequency graph for your table.

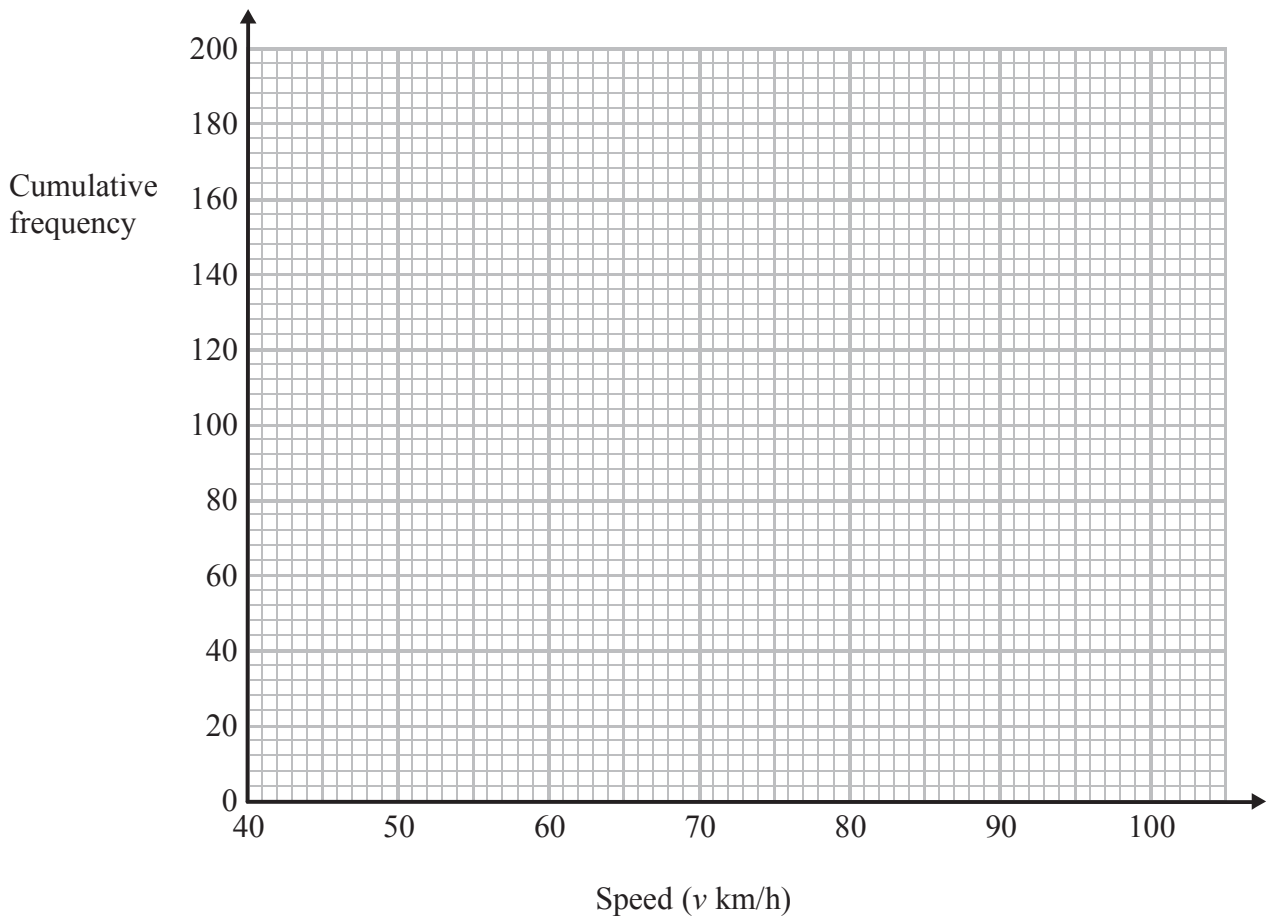

(2)

(e) The police decide to fine the driver of any vehicle passing the speed checkpoint at a speed of more than 84 km/h.  
Use your graph to find an estimate for the number of drivers the police decide to fine.  
Show your method clearly.

.....  
(2)

(Total for Question 11 is 8 marks)

**Do NOT write in this space.**



12 (a) Helen's savings increased from £155 to £167.40

Work out the percentage increase in Helen's savings.

..... %

(3)

(b) Joe's savings increased by 4.5%.

His savings are now £125.40

What were his savings before the increase?

£.....

(3)

**(Total for Question 12 is 6 marks)**

**Do NOT write in this space.**



13

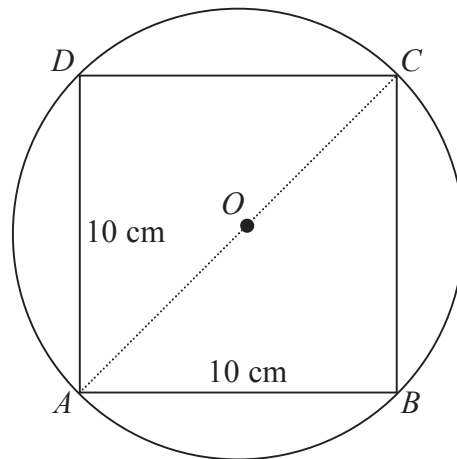

Diagram **NOT**  
accurately drawn

The diagram shows a square  $ABCD$  drawn inside a circle, centre  $O$ .  
 $A$ ,  $B$ ,  $C$  and  $D$  are points on the circle.  
 The lengths of the sides of the square are 10 cm.  
 $AC$  is a diameter of the circle.

Calculate the circumference of the circle.  
 Give your answer correct to 3 significant figures.

..... cm

(Total for Question 13 is 4 marks)



P 4 3 0 2 8 A 0 1 3 2 4

14 A farmer has 180 metres of fencing.

With the 180 metres of fencing, he makes an enclosure divided into eight equal, rectangular pens.

The fencing is used for the perimeter of each pen.

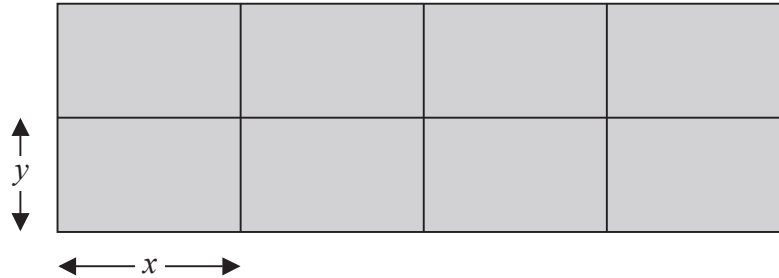

The length of each pen is  $x$  metres and the width of each pen is  $y$  metres.

(a) (i) Show that  $y = 18 - 1.2x$

The total area of the enclosure is  $A$  m<sup>2</sup>.

(ii) Show that  $A = 144x - 9.6x^2$

(3)

(b) Find  $\frac{dA}{dx}$

.....  
(2)

(c) Find the maximum value of  $A$ .

$A =$  .....  
(3)

(Total for Question 14 is 8 marks)



15 The diagram shows two regular hexagons,  $OABCDE$  and  $FGHIJ$ .

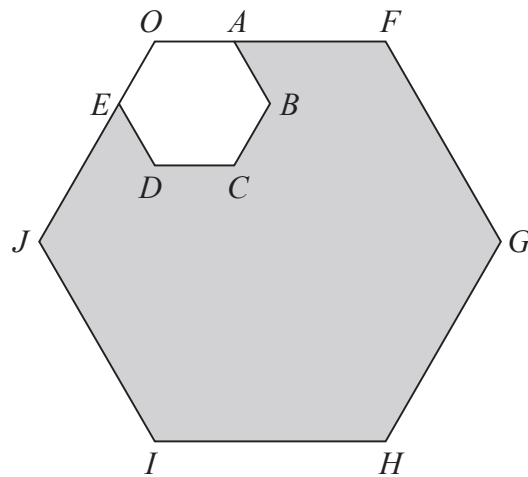

Diagram **NOT** accurately drawn

$OAF$  and  $OEJ$  are straight lines.

$OF = 3 OA$ .

The area of  $OABCDE$  is  $4 \text{ cm}^2$ .

Calculate the area of the shaded region.

.....  $\text{cm}^2$

(Total for Question 15 is 3 marks)

**Do NOT write in this space.**



16  $AEC$  and  $DEB$  are chords of a circle.

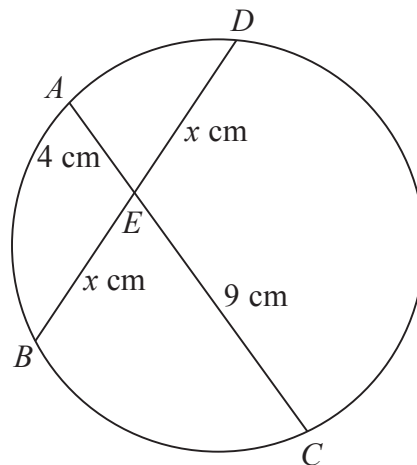

Diagram **NOT**  
accurately drawn

$$AE = 4 \text{ cm.}$$

$$CE = 9 \text{ cm.}$$

$$DE = BE = x \text{ cm.}$$

Calculate the value of  $x$ .

$$x = \dots\dots\dots$$

(Total for Question 16 is 2 marks)

17 Make  $x$  the subject of  $y = \sqrt{\frac{2x+1}{x-1}}$

.....

(Total for Question 17 is 4 marks)



18 A trapezium  $ABCD$  has an area of  $5\sqrt{6}$  cm<sup>2</sup>.

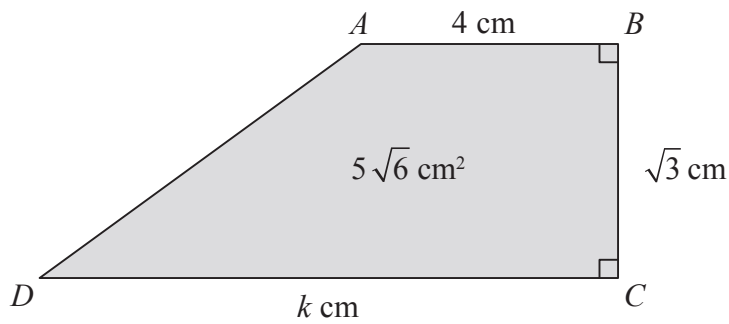

Diagram **NOT**  
accurately drawn

$$AB = 4 \text{ cm.}$$

$$BC = \sqrt{3} \text{ cm.}$$

$$DC = k \text{ cm.}$$

Calculate the value of  $k$ , giving your answer in the form  $a\sqrt{b} - c$   
where  $a$ ,  $b$  and  $c$  are positive integers.

Show each step in your working.

$$k = \dots\dots\dots$$

(Total for Question 18 is 3 marks)

**Do NOT write in this space.**



**19** Rachael walks to school.

The distance to school is 2.8 km, correct to the nearest 0.1 km.

She walks at a speed of 5 km/h, correct to the nearest km/h.

Calculate the upper bound, in minutes, for the time Rachael takes to walk to school.

..... minutes

**(Total for Question 19 is 3 marks)**

**Do NOT write in this space.**



- 20 Here are nine counters.  
Each counter has a number on it.

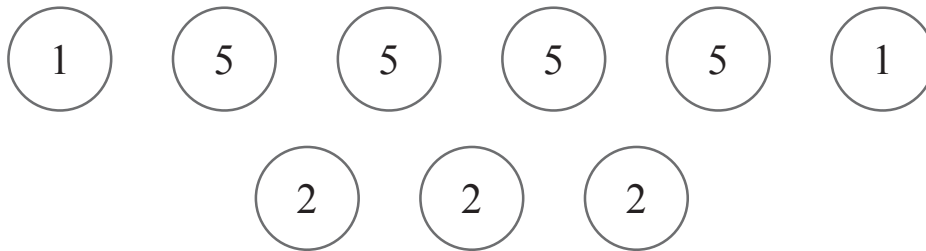

The counters are turned over to hide their numbers and are then mixed up.

Susan takes at random a counter and turns it over to reveal its number.  
She takes at random a second counter, from the remaining eight counters, and turns it over to reveal its number.

- (a) Calculate the probability that the number 5 is on both of the two counters Susan takes.

.....  
(2)

- (b) Calculate the probability that the sum of the numbers on the two counters Susan takes is divisible by 3

.....  
(3)

**(Total for Question 20 is 5 marks)**



21 The function  $f$  is defined as  $f(x) = \frac{3}{4+x}$

(a) Find the value of  $f(1)$

.....  
(1)

(b) State which value of  $x$  must be excluded from any domain of  $f$ .

.....  
(1)

The function  $g$  is defined as  $g(x) = 5 + x$

(c) Given that  $g(a) = 7$ , find the value of  $a$ .

$a =$  .....  
(1)

(d) Calculate  $fg(1)$

.....  
(2)

(e) Find  $fg(x)$   
Simplify your answer.

$fg(x) =$  .....  
(2)

**(Total for Question 21 is 7 marks)**



22 The diagram shows a metal plate.

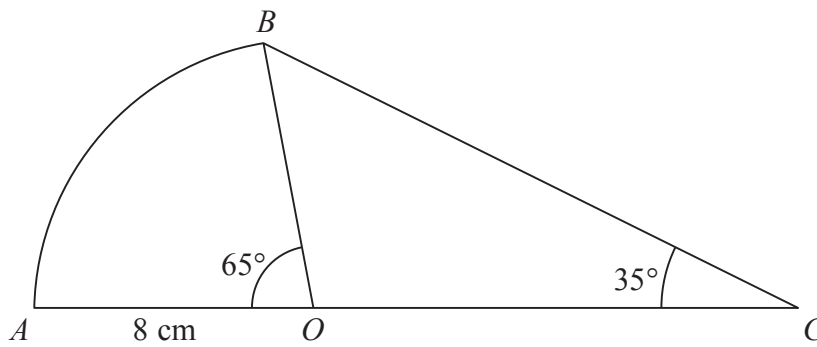

Diagram **NOT**  
accurately drawn

The metal plate is made from a sector  $OAB$  of a circle, centre  $O$ , and a triangle  $OCB$ .

Angle  $AOB = 65^\circ$  Angle  $OCB = 35^\circ$

$OA = OB = 8$  cm.

$AOC$  is a straight line.

- (a) Calculate the length of  $BC$ .  
Give your answer correct to 3 significant figures.

..... cm  
(3)

- (b) Calculate the total area of the metal plate.  
Give your answer correct to 3 significant figures.

..... cm<sup>2</sup>  
(4)

(Total for Question 22 is 7 marks)



23 Solve the equation  $\frac{3}{(x+2)} + \frac{4}{(x-3)} = 2$

Show clear algebraic working.

.....  
(Total for Question 23 is 5 marks)

---

TOTAL FOR PAPER IS 100 MARKS



**BLANK PAGE**

**Do NOT write in this space.**



P 4 3 0 2 8 A 0 2 3 2 4

**BLANK PAGE**

**Do NOT write in this space.**

