

Write your name here

Surname

Other names

**Pearson Edexcel
International GCSE**

Centre Number

--	--	--	--	--	--

Candidate Number

--	--	--	--	--

Mathematics A

Paper 4HR

Higher Tier

 Tuesday 19 January 2016 – Morning
Time: 2 hours

Paper Reference

4MA0/4HR
You must have:

Ruler graduated in centimetres and millimetres, protractor, compasses, pen, HB pencil, eraser, calculator. Tracing paper may be used.

Total Marks

Instructions

- Use **black** ink or ball-point pen.
- **Fill in the boxes** at the top of this page with your name, centre number and candidate number.
- Answer **all** questions.
- Without sufficient working, correct answers may be awarded no marks.
- Answer the questions in the spaces provided
– *there may be more space than you need.*
- **Calculators may be used.**
- You must **NOT** write anything on the formulae page.
Anything you write on the formulae page will gain NO credit.

Information

- The total mark for this paper is 100.
- The marks for **each** question are shown in brackets
– *use this as a guide as to how much time to spend on each question.*

Advice

- Read each question carefully before you start to answer it.
- Check your answers if you have time at the end.

Turn over ►

P46917A

©2016 Pearson Education Ltd.

1/1/1

PEARSON

**International GCSE MATHEMATICS
FORMULAE SHEET – HIGHER TIER**

Pythagoras' Theorem

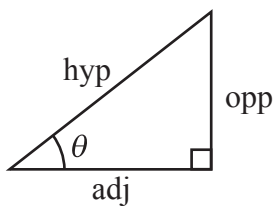
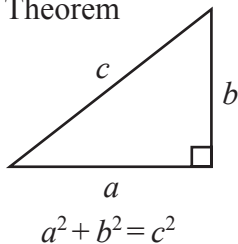

adj = hyp \times cos θ
opp = hyp \times sin θ
opp = adj \times tan θ

or $\sin \theta = \frac{\text{opp}}{\text{hyp}}$

$\cos \theta = \frac{\text{adj}}{\text{hyp}}$

$\tan \theta = \frac{\text{opp}}{\text{adj}}$

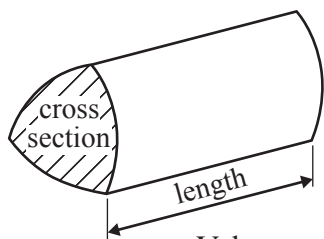

Volume of prism = area of cross section \times length

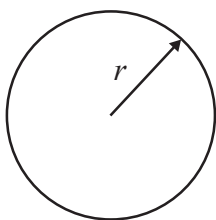

Circumference of circle = $2\pi r$

Area of circle = πr^2

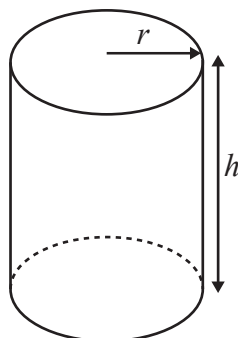

Volume of cylinder = $\pi r^2 h$

Curved surface area of cylinder = $2\pi r h$

Volume of cone = $\frac{1}{3} \pi r^2 h$

Curved surface area of cone = $\pi r l$

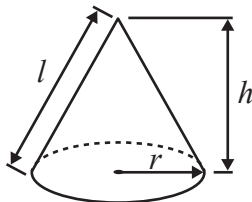

Volume of sphere = $\frac{4}{3} \pi r^3$

Surface area of sphere = $4\pi r^2$

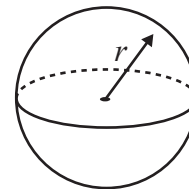

In any triangle ABC

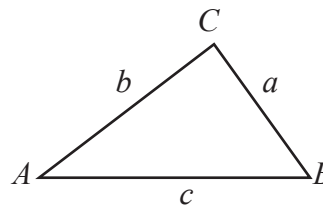

Sine rule: $\frac{a}{\sin A} = \frac{b}{\sin B} = \frac{c}{\sin C}$

Cosine rule: $a^2 = b^2 + c^2 - 2bc \cos A$

Area of triangle = $\frac{1}{2} ab \sin C$

Area of a trapezium = $\frac{1}{2}(a + b)h$

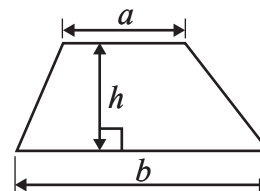

The Quadratic Equation

The solutions of $ax^2 + bx + c = 0$, where $a \neq 0$, are given by

$$x = \frac{-b \pm \sqrt{b^2 - 4ac}}{2a}$$

DO NOT WRITE IN THIS AREA

DO NOT WRITE IN THIS AREA

DO NOT WRITE IN THIS AREA



Answer ALL TWENTY FOUR questions.

Write your answers in the spaces provided.

You must write down all the stages in your working.

- 1 Here is a list of ingredients needed to make 16 cookies.

Ingredients for 16 cookies
120 g butter
150 g sugar
240 g flour
170 g chocolate
1 egg

Max wants to make 40 cookies.

- (a) How much flour does Max need?

..... g
(2)

Abby made cookies to sell at a school fair.
She used 600 g of butter.

- (b) How many cookies did she make?

.....
(2)

- (c) Find the ratio of the weight of sugar to the weight of flour in the list of ingredients.
Give your answer in the form 1: n

1 :
(2)

(Total for Question 1 is 6 marks)



2

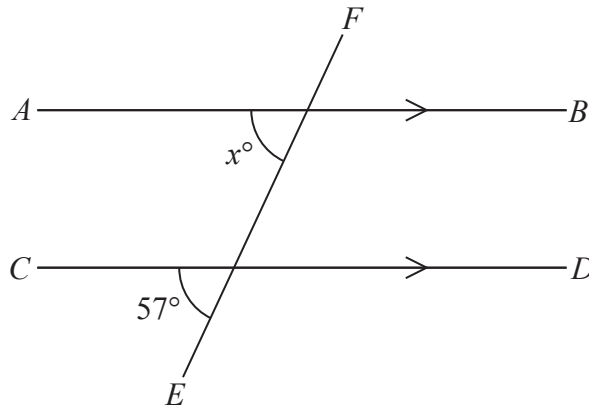

Diagram **NOT** accurately drawn

AB is parallel to CD
 EF is a straight line.

(a) (i) Find the value of x

$x = \dots\dots\dots$

(ii) Give a reason for your answer.

(2)

Here is a pentagon.

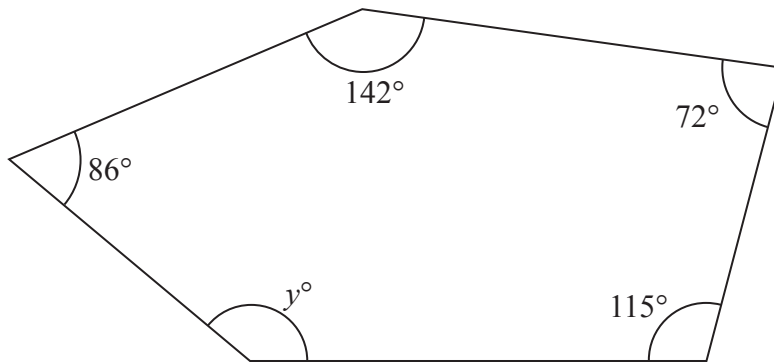

Diagram **NOT** accurately drawn

(b) Work out the value of y .

$y = \dots\dots\dots$

(3)

(Total for Question 2 is 5 marks)



DO NOT WRITE IN THIS AREA

DO NOT WRITE IN THIS AREA

DO NOT WRITE IN THIS AREA

3 Show that $\frac{3}{4} + \frac{4}{5} = 1\frac{11}{20}$

(Total for Question 3 is 2 marks)

- 4 $\mathcal{E} = \{\text{whole numbers}\}$
 $A = \{\text{factors of 100}\}$
 $B = \{\text{multiples of 5}\}$
List the members of the set $A \cap B$

(Total for Question 4 is 2 marks)



5 Here are a rectangle and a square.

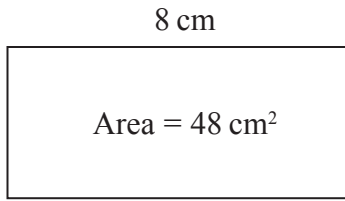

Diagram **NOT** accurately drawn

The rectangle has length 8 cm and area 48 cm^2
The perimeter of the square is the same as the perimeter of the rectangle.
Calculate the area of the square.

..... cm^2

(Total for Question 5 is 4 marks)

DO NOT WRITE IN THIS AREA

DO NOT WRITE IN THIS AREA

DO NOT WRITE IN THIS AREA



6 (a) Simplify $x^7 \times x^2$

.....
(1)

(b) Simplify $y^9 \div y^3$

.....
(1)

(c) Expand and simplify $4(2d + 3) - 2(3d - 5)$

.....
(2)

(d) Solve $9y - 3 = 5y + 2$

$y =$
(2)

(e) Solve $\frac{7x - 1}{5} = x$

Show clear algebraic working.

$x =$
(3)

(Total for Question 6 is 9 marks)



- 7 Mr Rowland has a class of 30 students.
He gave them 24 words to spell.
The table shows information about the number of correct spellings for each student.

Number of correct spellings	Frequency
0 – 4	1
5 – 9	5
10 – 14	6
15 – 19	10
20 – 24	8

- (a) Write down the modal class.

.....
(1)

- (b) Work out an estimate for the mean number of correct spellings.
Give your answer to 1 decimal place.

.....
(4)

(Total for Question 7 is 5 marks)



8 Ying eats some yoghurt.

The yoghurt contains 192 mg of calcium.

This is 16% of the total amount of calcium that Ying should have each day.

Work out the total amount of calcium that Ying should have each day.



..... mg

(Total for Question 8 is 3 marks)

9 A plane flew from Bogotá to Quito.

The distance the plane flew was 725 km.

The time taken by the plane was 1 hour 24 minutes.

Work out the average speed of the plane.

Give your answer correct to 3 significant figures.

..... km/h

(Total for Question 9 is 3 marks)



10 The table gives the surface areas, in square kilometres, of five seas.

Sea	Surface area in square kilometres
Mediterranean Sea	2.97×10^6
East China Sea	1.25×10^6
Baltic Sea	4.22×10^5
Red Sea	4.38×10^5
Okhotsk Sea	1.59×10^6

(a) Write 1.59×10^6 as an ordinary number.

.....
(1)

(b) Work out the difference, in square kilometres, between the largest surface area and the smallest surface area for these five seas.
Give your answer in standard form.

..... km²
(2)

The surface area of the East China Sea is k times the surface area of the Baltic Sea.

(c) Work out the value of k .
Give your answer to the nearest whole number.

$k =$
(2)

(Total for Question 10 is 5 marks)



11

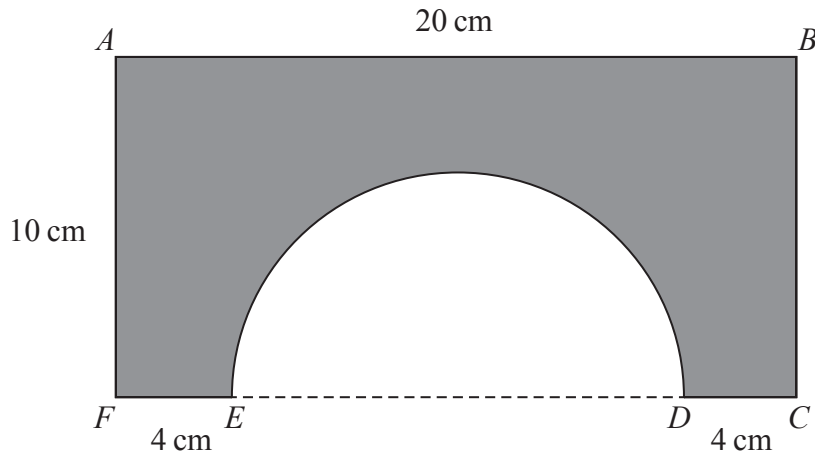

Diagram **NOT**
accurately drawn

The shaded shape is made by cutting a semicircle from a rectangular piece of card, $ABCF$, as shown in the diagram.

$FEDC$ is a straight line.

The centre of the semicircle lies on ED .

$AF = BC = 10$ cm, $AB = 20$ cm, $FE = DC = 4$ cm.

Work out the perimeter of the shaded shape.

Give your answer correct to 3 significant figures.

..... cm

(Total for Question 11 is 3 marks)



12 Simplify fully $(2x + 3)^2 - (2x - 3)^2$

DO NOT WRITE IN THIS AREA

DO NOT WRITE IN THIS AREA

(Total for Question 12 is 3 marks)

DO NOT WRITE IN THIS AREA



13 The diagram shows triangle ABC .

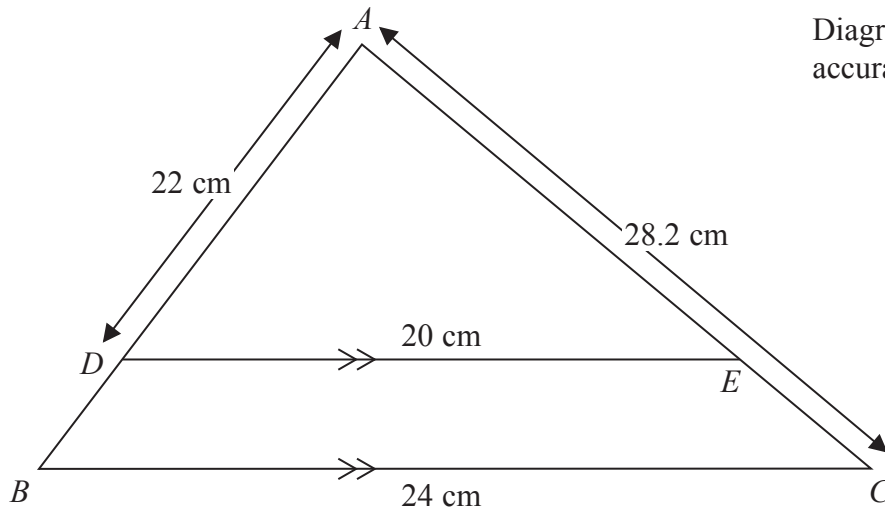

Diagram NOT accurately drawn

ADB and AEC are straight lines.

DE is parallel to BC .

$DE = 20$ cm, $BC = 24$ cm, $AD = 22$ cm, $AC = 28.2$ cm

(a) Work out the length of AB .

..... cm
(2)

(b) Work out the length of EC .

..... cm
(2)

(Total for Question 13 is 4 marks)

DO NOT WRITE IN THIS AREA



14 (a) Complete the table of values for $y = x^3 - 5x + 2$

x	-3	-2	-1	0	1	2	3
y		4			-2		14

(2)

(b) On the grid, draw the graph of $y = x^3 - 5x + 2$ for $-3 \leq x \leq 3$

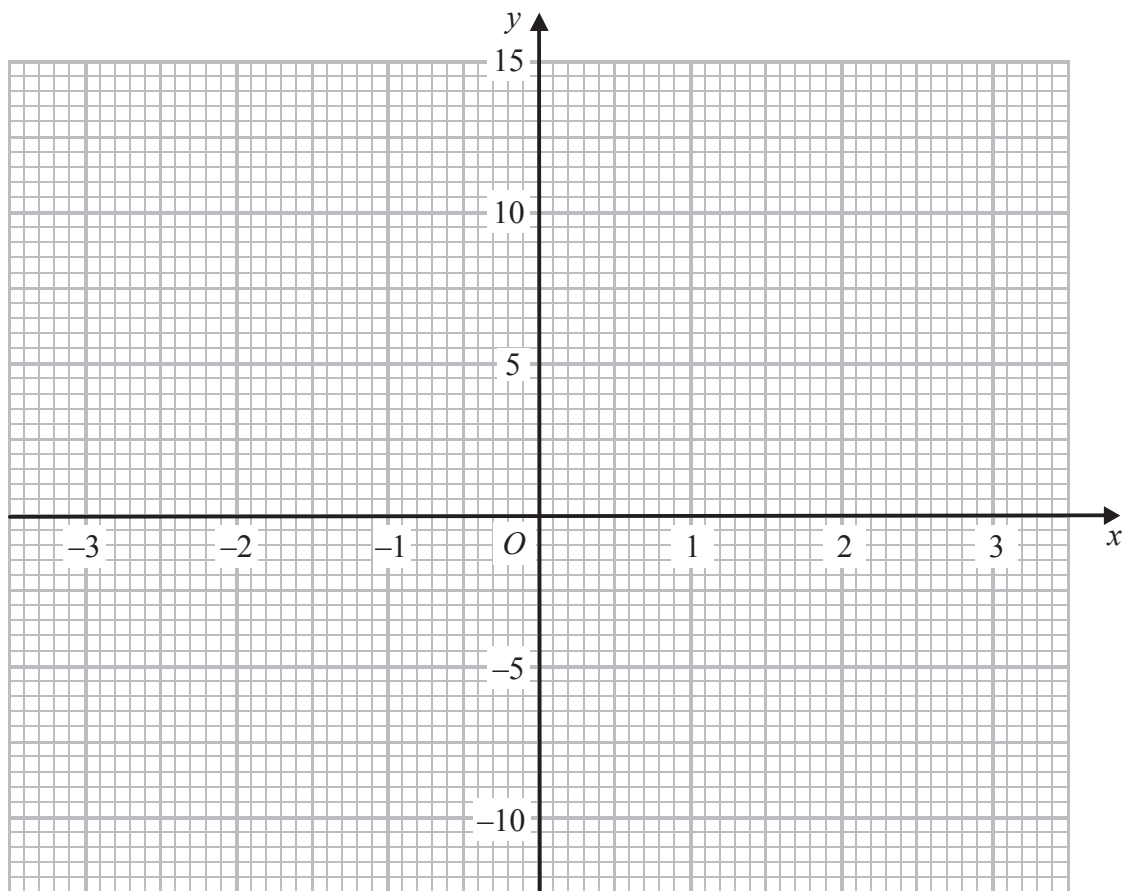

(2)

DO NOT WRITE IN THIS AREA

DO NOT WRITE IN THIS AREA

DO NOT WRITE IN THIS AREA



The equation $x^3 - 6x + m = 0$, where m is an integer, has one negative solution and two positive solutions.

(c) Given that $x = 1$ is one of the positive solutions, show that $m = 5$

(1)

(d) By drawing a suitable straight line on the grid, find an estimate for the negative solution of $x^3 - 6x + 5 = 0$
Give your estimate to 1 decimal place.

.....
(2)

(Total for Question 14 is 7 marks)



15 Use algebra to show that the recurring decimal $0.2\dot{6} = \frac{4}{15}$

(Total for Question 15 is 2 marks)

16 Q is inversely proportional to t^2
 $Q = 320$ when $t = 0.5$

Find a formula for Q in terms of t

(Total for Question 16 is 3 marks)

DO NOT WRITE IN THIS AREA

DO NOT WRITE IN THIS AREA

DO NOT WRITE IN THIS AREA



DO NOT WRITE IN THIS AREA

17 Chaiwat either cycles to work or goes by bus.

On any day that he goes to work, the probability that he cycles is 0.6
 When he cycles, the probability that he is late is 0.1
 When he goes by bus, the probability that he is late is 0.3

(a) Complete the probability tree diagram.

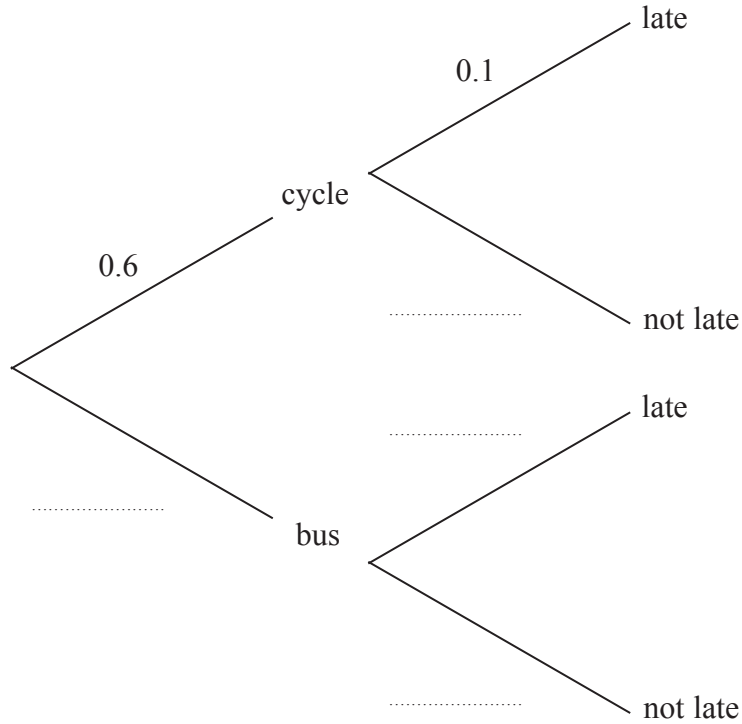

(2)

(b) Calculate the probability that on a day Chaiwat goes to work, he cycles and is late for work.

.....
(2)

(c) Calculate the probability that on a day Chaiwat goes to work, he is **not** late for work.

.....
(3)

(Total for Question 17 is 7 marks)



- 18 The incomplete histogram and the incomplete table show information about the ages of people watching a film in a cinema.

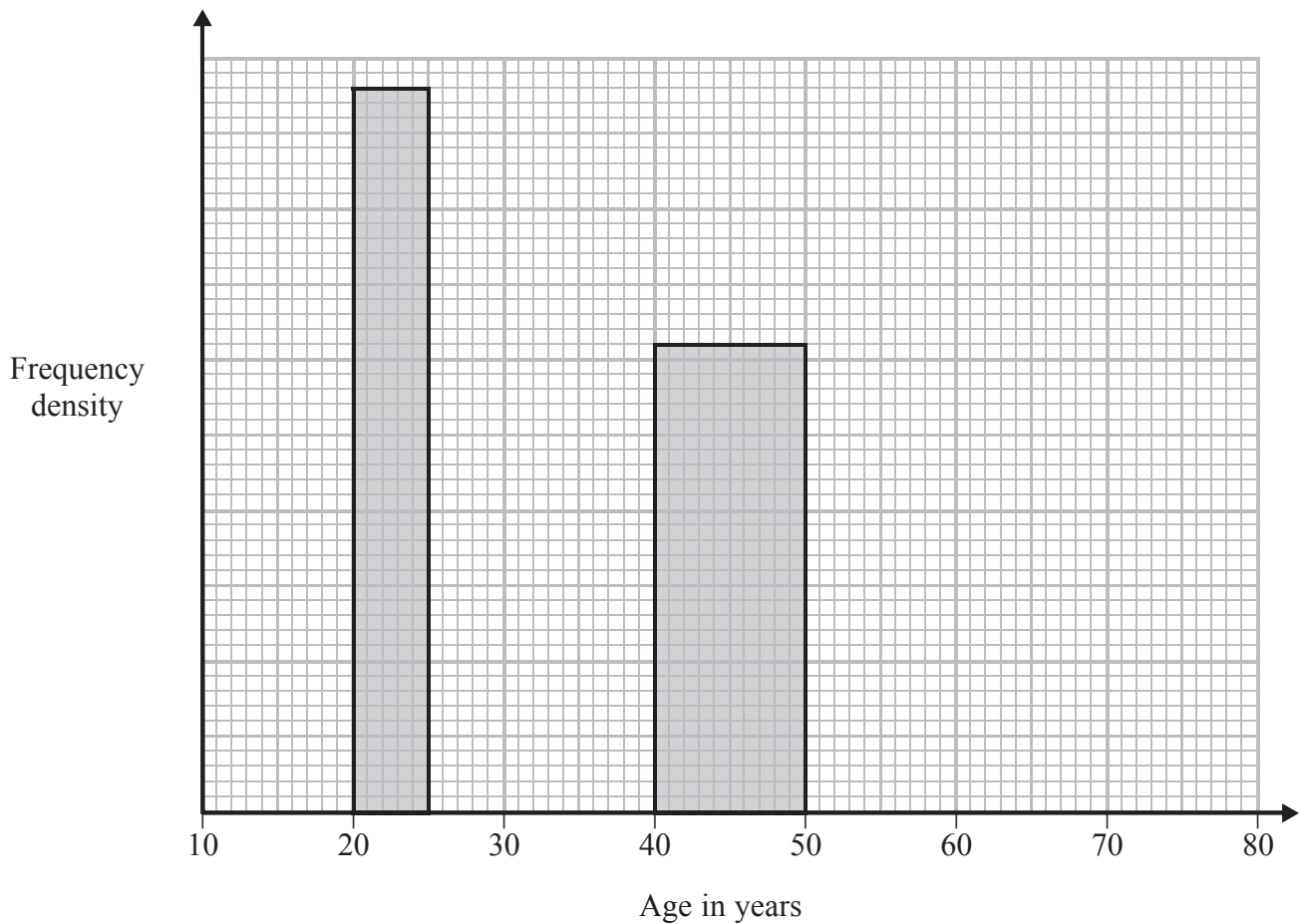

Age (a years)	Number of people
$10 \leq a < 20$	38
$20 \leq a < 25$	24
$25 \leq a < 40$	63
$40 \leq a < 50$	
$50 \leq a < 80$	24

- (a) Use the histogram to complete the table.

(2)

- (b) Use the table to complete the histogram.

(2)

(Total for Question 18 is 4 marks)



19 Make g the subject of $3e + 4g = 7 + 9eg$

.....
(Total for Question 19 is 3 marks)

20 Express $\frac{3}{x+2} - \frac{6}{2x+5}$ as a single fraction.

Simplify your answer.

.....
(Total for Question 20 is 3 marks)



21 $ABCDE$ is a square-based pyramid.

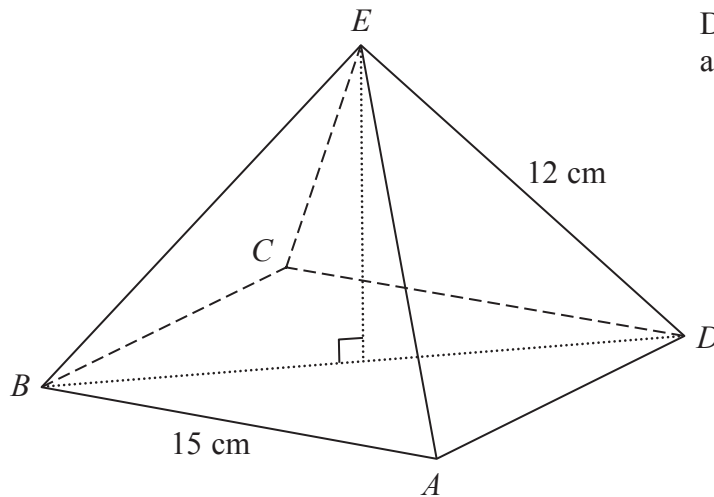

Diagram **NOT**
accurately drawn

$$AE = BE = CE = DE = 12 \text{ cm}$$

$$AB = 15 \text{ cm}$$

Calculate the size of angle DEB .

Give your answer to the nearest degree.



22 $(a + \sqrt{b})^2 = 49 + 12\sqrt{b}$ where a and b are integers, and b is prime.

Find the value of a and the value of b

$a =$

$b =$

(Total for Question 22 is 3 marks)

23 ABC is a triangle.

$AB = 12$ cm

$AC = 14$ cm

The area of triangle ABC is 72 cm²

Find, in degrees, the two possible sizes of angle BAC .

Give your answers correct to the nearest degree.

.....
(Total for Question 23 is 4 marks)



24 Solve the simultaneous equations

$$y = 3x + 2$$
$$x^2 + y^2 = 20$$

Show clear algebraic working.

DO NOT WRITE IN THIS AREA

DO NOT WRITE IN THIS AREA

DO NOT WRITE IN THIS AREA

(Total for Question 24 is 6 marks)

TOTAL FOR PAPER IS 100 MARKS



DO NOT WRITE IN THIS AREA

DO NOT WRITE IN THIS AREA

DO NOT WRITE IN THIS AREA

BLANK PAGE

Do NOT write on this page.



P 4 6 9 1 7 A 0 2 3 2 4

DO NOT WRITE IN THIS AREA

DO NOT WRITE IN THIS AREA

DO NOT WRITE IN THIS AREA

BLANK PAGE

Do NOT write on this page.

