

Write your name here

Surname	Other names
---------	-------------

Pearson Edexcel
International GCSE

Centre Number

--	--	--	--	--

Candidate Number

--	--	--	--

Mathematics B

Paper 1R



Monday 9 January 2017 – Morning
Time: 1 hour 30 minutes

Paper Reference

4MB0/01R

You must have: Ruler graduated in centimetres and millimetres, protractor, compasses, pen, HB pencil, eraser, calculator. Tracing paper may be used.

Total Marks

Instructions

- Use **black** ink or ball-point pen.
- **Fill in the boxes** at the top of this page with your name, centre number and candidate number.
- Answer **all** questions.
- Answer the questions in the spaces provided
– *there may be more space than you need.*
- **Calculators may be used.**

Information

- The total mark for this paper is 100.
- The marks for **each** question are shown in brackets
– *use this as a guide as to how much time to spend on each question.*

Advice

- Read each question carefully before you start to answer it.
- Check your answers if you have time at the end.
- Without sufficient working, correct answers may be awarded no marks.

Turn over ►

P48411A

©2017 Pearson Education Ltd.

1/1/1/1/



Pearson

Answer ALL TWENTY NINE questions.

Write your answers in the spaces provided.

You must write down all the stages in your working.

1

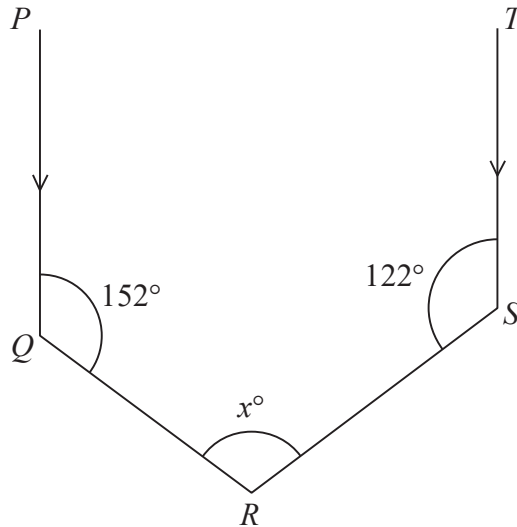

Diagram NOT
accurately drawn

In the diagram, PQ is parallel to TS , $\angle PQR = 152^\circ$, $\angle TSR = 122^\circ$ and $\angle QRS = x^\circ$

Find the value of x .

$x = \dots\dots\dots$

(Total for Question 1 is 2 marks)

- 2 Express 275 g as a fraction of 5.5 kg.
Give your answer in its simplest form.

$\dots\dots\dots$

(Total for Question 2 is 2 marks)



DO NOT WRITE IN THIS AREA

3 Solve $\frac{2}{3}x - \frac{8}{15}x = \frac{16}{5}$

Show all your working clearly.

$$x = \dots\dots\dots$$

(Total for Question 3 is 2 marks)

4 Each time a music track was downloaded, the music company received £0.95

The music company gave $12\frac{1}{2}\%$ of the money received to the singer of the track.

The music track was downloaded 32 000 times in November.

Calculate how much, in £, was given to the singer by the music company for the November music track downloads.

$$\text{£ } \dots\dots\dots$$

(Total for Question 4 is 2 marks)

5 The n th term of a sequence is given by the expression $5 - 3n$

Find the difference between the 7th term and the 12th term.

$$\dots\dots\dots$$

(Total for Question 5 is 2 marks)

DO NOT WRITE IN THIS AREA

DO NOT WRITE IN THIS AREA



6 Factorise completely $xw - yw - yz + xz$

.....
(Total for Question 6 is 2 marks)

7 Given that $y = x^6 - \frac{6}{x^3}$

find $\frac{dy}{dx}$

.....
(Total for Question 7 is 2 marks)

DO NOT WRITE IN THIS AREA

DO NOT WRITE IN THIS AREA

DO NOT WRITE IN THIS AREA



8

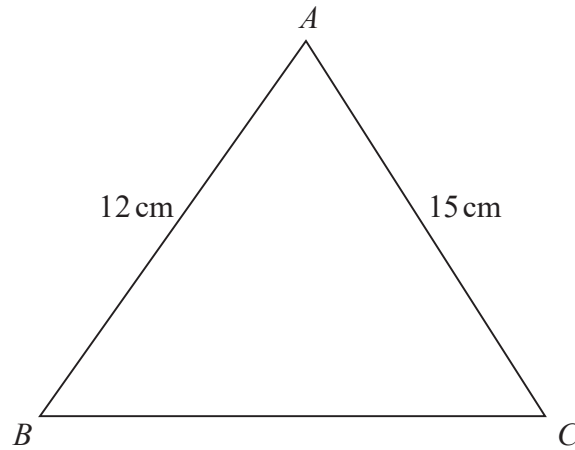

Diagram **NOT**
accurately drawn

In triangle ABC , $AB = 12$ cm and $AC = 15$ cm.
The area of triangle ABC is 35 cm²

Calculate the value of $\sin A$

$\sin A = \dots\dots\dots$

(Total for Question 8 is 2 marks)

9 Showing all your working, evaluate $\frac{3^{-2} + 5^3}{3^{-2}}$

(Total for Question 9 is 2 marks)



$$10 \quad t = \frac{2 \cos p^\circ - 1}{\sqrt{q} - r}$$

where $p = 30$, $q = 12288$ and $r = 64$

- (a) Find the exact value of t .
Give your answer as a decimal.

$$t = \dots\dots\dots (2)$$

- (b) Write your answer to part (a) to 4 significant figures.

$$\dots\dots\dots (1)$$

(Total for Question 10 is 3 marks)

- 11 $\mathcal{E} = \{1, 2, 3, 4, 5, 6, 7, 8, 9, 10\}$
 $A = \{\text{odd numbers}\}$
 $B = \{\text{multiples of 3}\}$
 $C = \{\text{factors of 24}\}$

List the elements of the set

- (a) A'

$$A' = \{\dots\dots\dots\} (1)$$

- (b) $B \cup C$

$$B \cup C = \{\dots\dots\dots\} (1)$$

- (c) $A' \cap (B \cup C)$

$$A' \cap (B \cup C) = \{\dots\dots\dots\} (1)$$

(Total for Question 11 is 3 marks)



DO NOT WRITE IN THIS AREA

DO NOT WRITE IN THIS AREA

DO NOT WRITE IN THIS AREA

12 Find the matrix product

(a) $(3 \quad -2) \begin{pmatrix} 1 \\ -4 \end{pmatrix}$

.....
(1)

(b) $\begin{pmatrix} 1 \\ -4 \end{pmatrix} (3 \quad -2)$

.....
(2)

(Total for Question 12 is 3 marks)

13 Simplify fully $\frac{6x^3 - 12x^2y}{4xy - 8y^2}$

.....
(Total for Question 13 is 3 marks)



14 Here are the mathematics test results of 12 students.

9 8 6 8 5 4 8 10 6 9 4 5

(a) Find the median mark.

.....
(2)

(b) Write down the modal mark.

.....
(1)

(Total for Question 14 is 3 marks)

15 Make y the subject of $4x - 5(y + 3) = wy$

.....
(Total for Question 15 is 3 marks)

DO NOT WRITE IN THIS AREA

DO NOT WRITE IN THIS AREA

DO NOT WRITE IN THIS AREA



DO NOT WRITE IN THIS AREA

16 (a) Write down **any** number a for which $\sqrt{a} > a$

$a = \dots\dots\dots$
(1)

(b) x is a positive number and $10\sqrt{x} = x\sqrt{40}$

Showing all your working, find the value of x .

$x = \dots\dots\dots$
(2)

(Total for Question 16 is 3 marks)

17 Solve $3x - 2y = 11$

$5x - 3y = 18$

$x = \dots\dots\dots$ $y = \dots\dots\dots$

(Total for Question 17 is 4 marks)

DO NOT WRITE IN THIS AREA

DO NOT WRITE IN THIS AREA



18 $a:b = 5:8$ and $b:c = 6:25$

Find, in its simplest form, $a:b:c$

$a:b:c = \dots\dots\dots$

(Total for Question 18 is 3 marks)

19

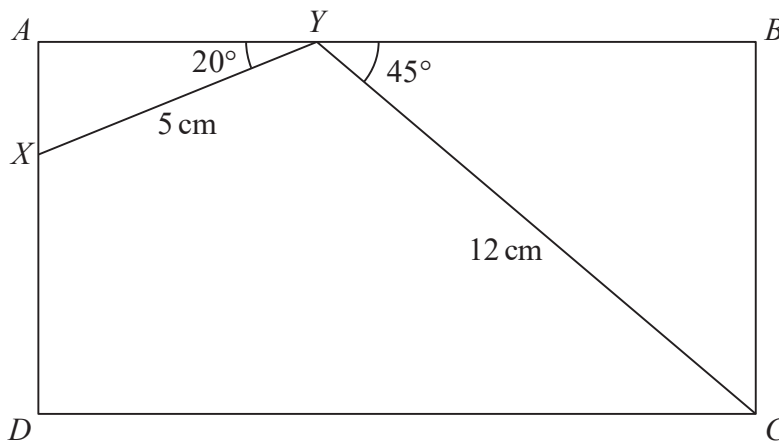

Diagram **NOT** accurately drawn

$ABCD$ is a rectangle.

X is the point on AD and Y is the point on AB such that $XY = 5$ cm, $YC = 12$ cm, $\angle BYC = 45^\circ$ and $\angle AXY = 20^\circ$

Find the length, in cm to 3 significant figures, of

(a) BC ,

$BC = \dots\dots\dots$ cm
(2)

(b) AB .

$AB = \dots\dots\dots$ cm
(2)

(Total for Question 19 is 4 marks)

DO NOT WRITE IN THIS AREA

DO NOT WRITE IN THIS AREA

DO NOT WRITE IN THIS AREA



DO NOT WRITE IN THIS AREA

20 A biased six-sided die is numbered 1, 2, 3, 4, 5 and 6.

The table shows the probability of each possible score when the die is rolled once.

Score	1	2	3	4	5	6
Probability	0.2	0.1	x	0.15	0.3	0.1

(a) Find the value of x .

$$x = \dots\dots\dots (1)$$

The die is to be rolled twice.

(b) Find the probability that the sum of the scores for the two rolls is 10.

$$\dots\dots\dots (3)$$

(Total for Question 20 is 4 marks)

21 (a) Express 729 as a power of 3

$$\dots\dots\dots (1)$$

(b) Hence solve $3^{2x+5} = 729^{5-x}$

Show your working clearly.

$$x = \dots\dots\dots (3)$$

(Total for Question 21 is 4 marks)

DO NOT WRITE IN THIS AREA

DO NOT WRITE IN THIS AREA



- 22 Each day, Sania recorded the maximum wind speed, in km/h, in her town for a period of 60 days. On no day was the maximum wind speed greater than 60 km/h.

The incomplete table and histogram give information about the maximum wind speeds.

Using this information

- (a) complete the table,

Maximum wind speed (s km/h)	Number of days
$0 < s \leq 10$	8
$10 < s \leq 25$	24
$25 < s \leq 40$	
$40 < s \leq 60$	

(2)

- (b) complete the histogram.

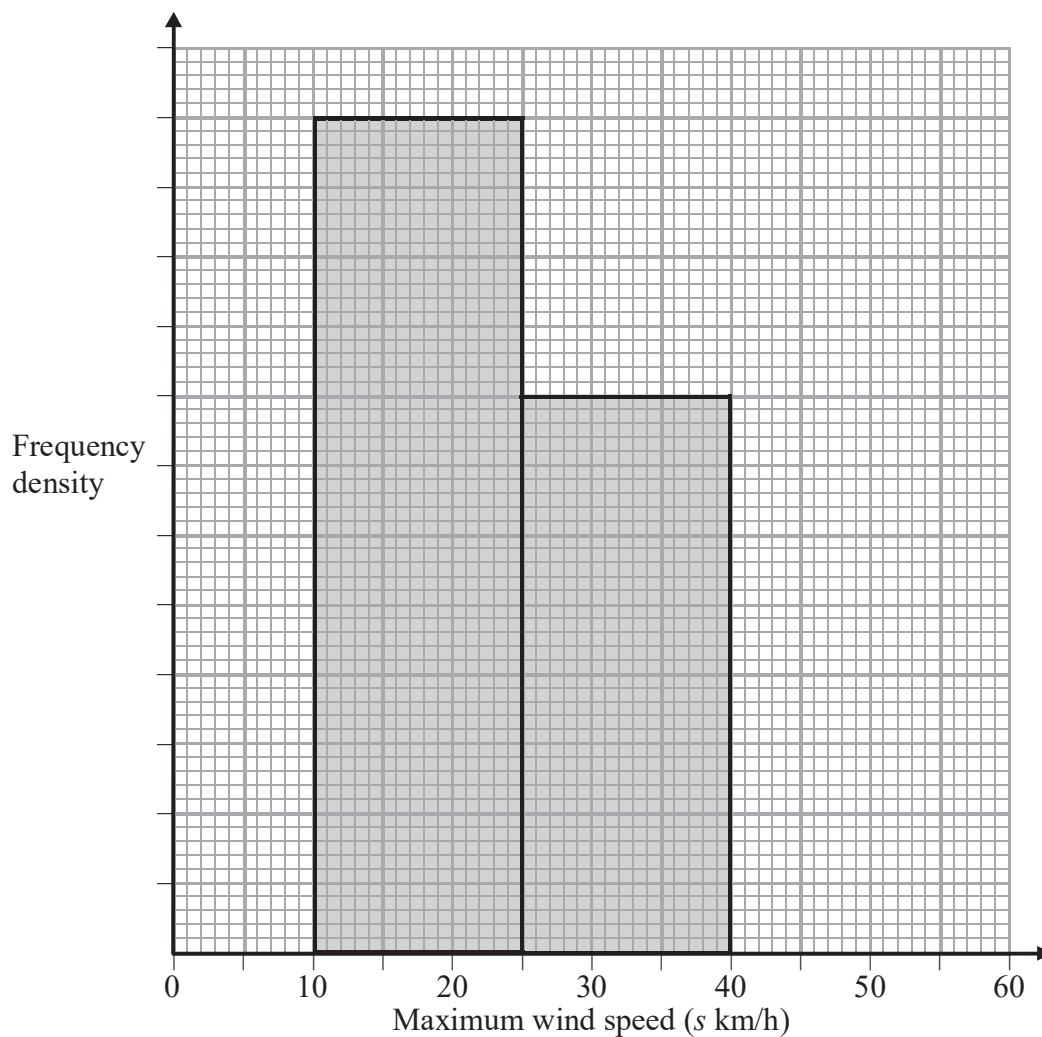

(2)

(Total for Question 22 is 4 marks)

DO NOT WRITE IN THIS AREA

DO NOT WRITE IN THIS AREA

DO NOT WRITE IN THIS AREA



23

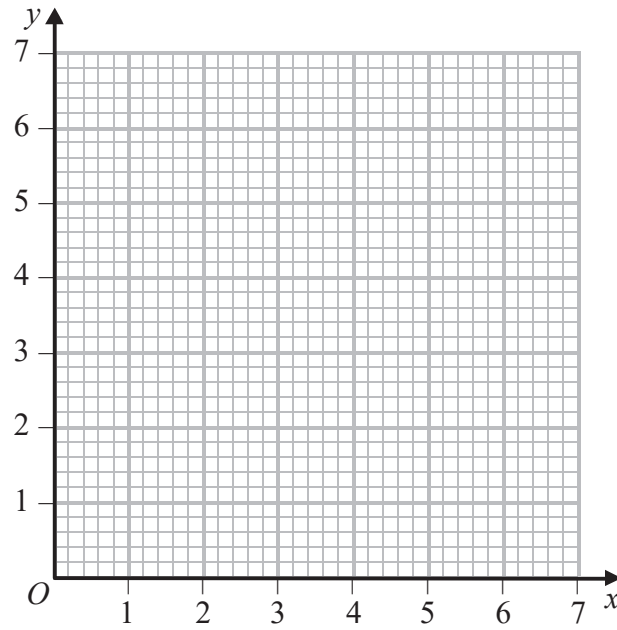

(a) On the grid, draw and label the lines with equation

(i) $y = 5$

(ii) $x + y = 6$

(iii) $2y = x + 1$

(3)

(b) On the grid, shade and label the region **R** defined by

$$x \geq 0 \quad \text{and} \quad y \leq 5 \quad \text{and} \quad x + y \leq 6 \quad \text{and} \quad 2y \geq x + 1$$

(1)

(Total for Question 23 is 4 marks)



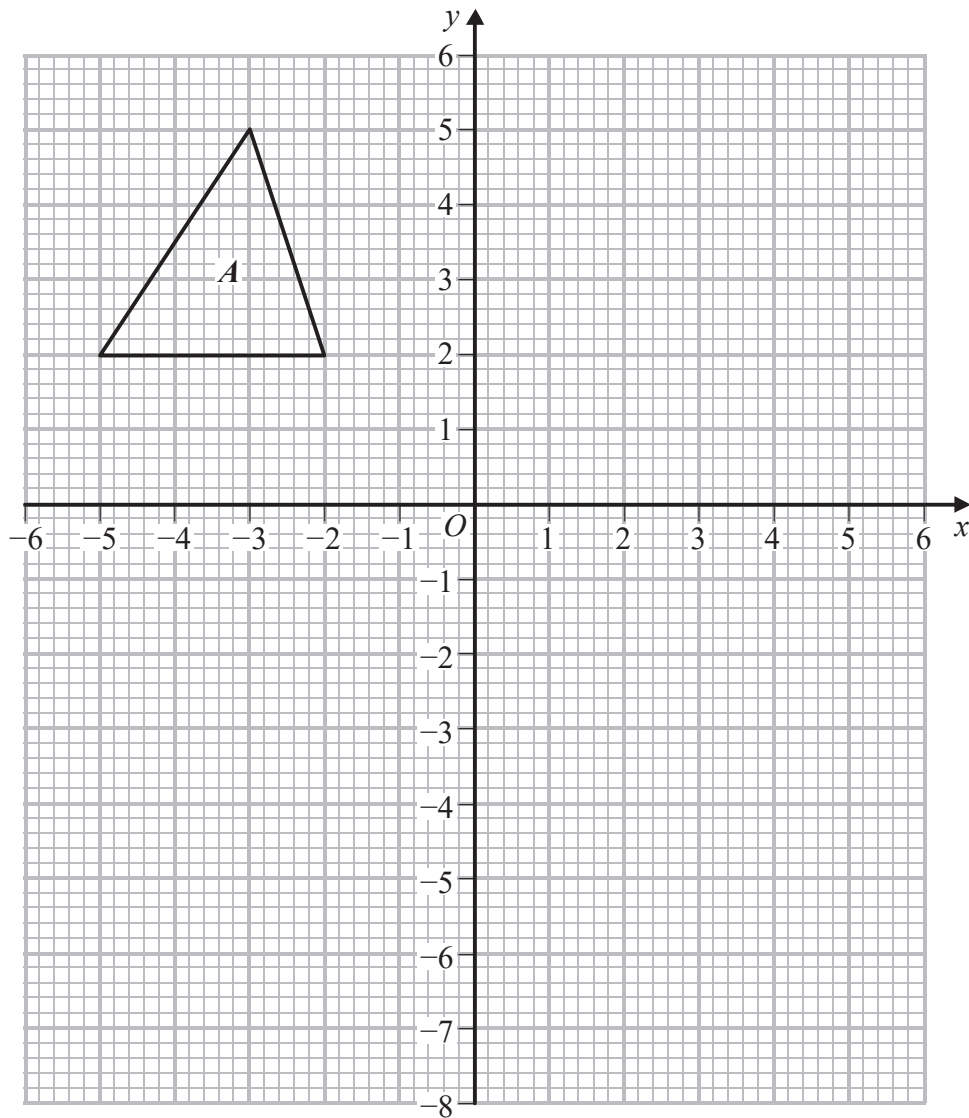

Triangle *B* is the image of triangle *A* under a reflection in the *x*-axis.

(a) On the grid, draw and label triangle *B*.

(1)

Triangle *C* is the image of triangle *B* under the translation $\begin{pmatrix} 7 \\ -2 \end{pmatrix}$

(b) On the grid, draw and label triangle *C*.

(1)

Triangle *D* is the image of triangle *C* under a rotation of 180° about the point $(3.5, -1)$

(c) On the grid, draw and label triangle *D*.

(1)

DO NOT WRITE IN THIS AREA

DO NOT WRITE IN THIS AREA

DO NOT WRITE IN THIS AREA



(d) Find the 2×2 matrix that represents the transformation of triangle D onto triangle A .

$$\begin{pmatrix} & \\ & \end{pmatrix}$$

(2)

(Total for Question 24 is 5 marks)

25 y varies directly as the cube of x .

$$y = 9 \text{ when } x = \frac{1}{2}$$

(a) Find a formula for y in terms of x .

$$y = \dots\dots\dots$$

(3)

(b) Find the value of x when $y = \frac{125}{3}$

$$x = \dots\dots\dots$$

(2)

(Total for Question 25 is 5 marks)

DO NOT WRITE IN THIS AREA

DO NOT WRITE IN THIS AREA

DO NOT WRITE IN THIS AREA



26

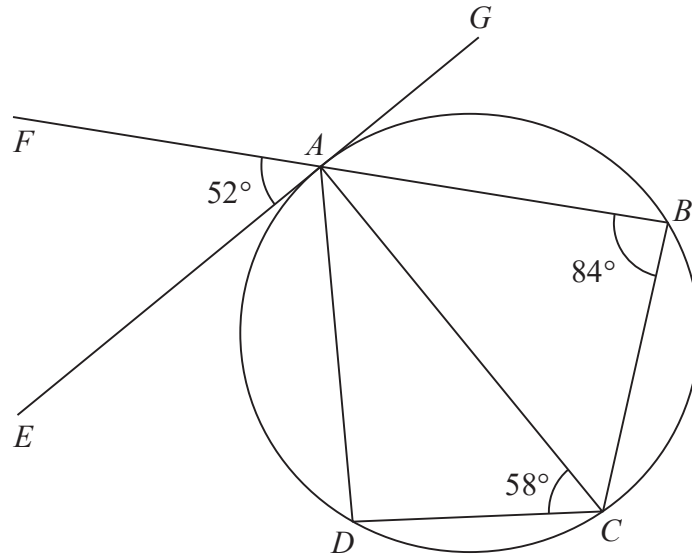

Diagram **NOT**
accurately drawn

In the diagram, A , B , C and D are points on the circumference of a circle. FAB is a straight line and EAG is the tangent to the circle at the point A .

$$\angle ABC = 84^\circ, \angle ACD = 58^\circ \text{ and } \angle EAF = 52^\circ$$

Giving your reasons, calculate the size, in degrees, of

(a) $\angle ADC$,

$$\angle ADC = \dots\dots\dots^\circ$$

(2)

(b) $\angle EAD$,

$$\angle EAD = \dots\dots\dots^\circ$$

(2)

DO NOT WRITE IN THIS AREA

DO NOT WRITE IN THIS AREA

DO NOT WRITE IN THIS AREA



(c) $\angle ACB$.

$$\angle ACB = \dots\dots\dots^\circ$$

(2)

(Total for Question 26 is 6 marks)

Do NOT write in this space

Turn over for Question 27

DO NOT WRITE IN THIS AREA

DO NOT WRITE IN THIS AREA

DO NOT WRITE IN THIS AREA



27 Find the values of x which satisfy $x + \frac{1}{x-2} = \frac{9}{2}$

DO NOT WRITE IN THIS AREA

DO NOT WRITE IN THIS AREA

DO NOT WRITE IN THIS AREA

.....
(Total for Question 27 is 5 marks)



28

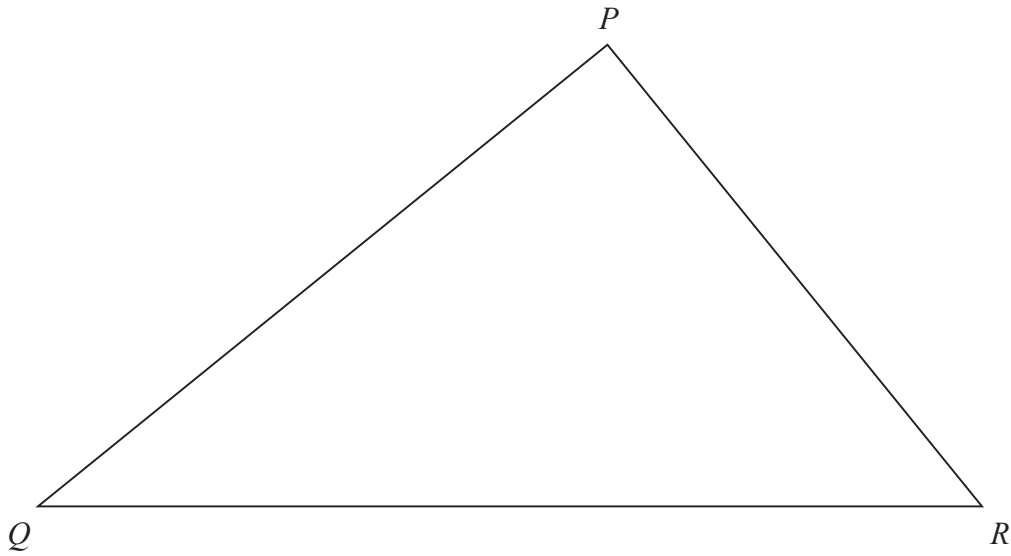

PQR is a triangle.

Leaving in all of your construction lines, construct the locus of all points inside the triangle which are

- (a) 6 cm from P , (1)
- (b) equidistant from Q and R , (2)
- (c) equidistant from the lines QP and QR . (2)

The region **T** consists of all the points inside the triangle which are less than 6 cm from P , closer to R than to Q and closer to QR than to QP .

- (d) Show, by shading, the region **T**. Label the region **T**. (1)

(Total for Question 28 is 6 marks)

Turn over for Question 29



P 4 8 4 1 1 A 0 1 9 2 4

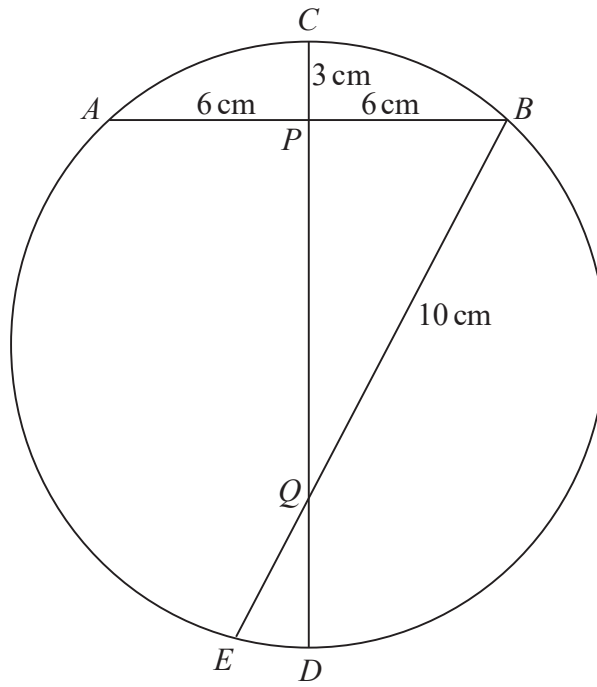

Diagram **NOT** accurately drawn

A, B, C, D and E are points on the circumference of a circle with diameter CD .

The chord AB of the circle intersects the diameter CD at P such that $AP = PB = 6\text{ cm}$ and $PC = 3\text{ cm}$.

The chord BE of the circle intersects the diameter at Q and $BQ = 10\text{ cm}$.

(a) Find the length, in cm, of PQ .

$PQ = \dots\dots\dots\text{ cm}$
(2)

(b) Find the radius, in cm, of the circle.

$\dots\dots\dots\text{ cm}$
(3)

DO NOT WRITE IN THIS AREA

DO NOT WRITE IN THIS AREA

DO NOT WRITE IN THIS AREA



(c) Find the length, in cm, of QE .

$QE = \dots\dots\dots$ cm
(2)

(Total for Question 29 is 7 marks)

TOTAL FOR PAPER IS 100 MARKS

DO NOT WRITE IN THIS AREA

DO NOT WRITE IN THIS AREA

DO NOT WRITE IN THIS AREA



DO NOT WRITE IN THIS AREA

DO NOT WRITE IN THIS AREA

DO NOT WRITE IN THIS AREA

BLANK PAGE



DO NOT WRITE IN THIS AREA

DO NOT WRITE IN THIS AREA

DO NOT WRITE IN THIS AREA

BLANK PAGE



P 4 8 4 1 1 A 0 2 3 2 4

DO NOT WRITE IN THIS AREA

DO NOT WRITE IN THIS AREA

DO NOT WRITE IN THIS AREA

BLANK PAGE

