

Write your name here

Surname	Other names
---------	-------------

**Pearson Edexcel**  
**International GCSE**

Centre Number

--	--	--	--	--

Candidate Number

--	--	--	--

# Mathematics B

## Paper 2



Thursday 9 June 2016 – Morning

**Time: 2 hours 30 minutes**

Paper Reference

**4MB0/02**

**You must have:** Ruler graduated in centimetres and millimetres, protractor, compasses, pen, HB pencil, eraser, calculator. Tracing paper may be used.

Total Marks

### Instructions

- Use **black** ink or ball-point pen.
- **Fill in the boxes** at the top of this page with your name, centre number and candidate number.
- Answer **all** questions.
- Answer the questions in the spaces provided  
– *there may be more space than you need.*
- **Calculators may be used.**

### Information

- The total mark for this paper is 100.
- The marks for **each** question are shown in brackets  
– *use this as a guide as to how much time to spend on each question.*

### Advice

- Read each question carefully before you start to answer it.
- Check your answers if you have time at the end.
- Without sufficient working, correct answers may be awarded no marks.

Turn over ►

P45918A

©2016 Pearson Education Ltd.

1/1/1/1/1/1/



**Answer ALL ELEVEN questions.**

**Write your answers in the spaces provided.**

**You must write down all the stages in your working.**

**1** The speed of an aeroplane can be measured in knots where 1 knot = 1.852 km/h.  
The speed of an aeroplane is 550 knots.

(a) Convert a speed of 550 knots to a speed in km/h.  
Give your answer to the nearest whole number.

(2)

A second aeroplane flies a distance of 1000 km in 2 hours.

(b) Calculate the average speed, in knots to the nearest whole number, of this second aeroplane.

(2)

.....

.....

.....

.....

.....

.....

.....

.....

.....

.....

.....

.....

.....

.....

.....

.....

.....

.....

.....

.....

.....

.....

DO NOT WRITE IN THIS AREA

DO NOT WRITE IN THIS AREA

DO NOT WRITE IN THIS AREA



**Question 1 continued**

DO NOT WRITE IN THIS AREA

DO NOT WRITE IN THIS AREA

DO NOT WRITE IN THIS AREA

Handwriting practice area with horizontal dotted lines.

**(Total for Question 1 is 4 marks)**





**Question 2 continued**

DO NOT WRITE IN THIS AREA

DO NOT WRITE IN THIS AREA

DO NOT WRITE IN THIS AREA

Handwriting practice area with horizontal dotted lines.

**(Total for Question 2 is 5 marks)**



3

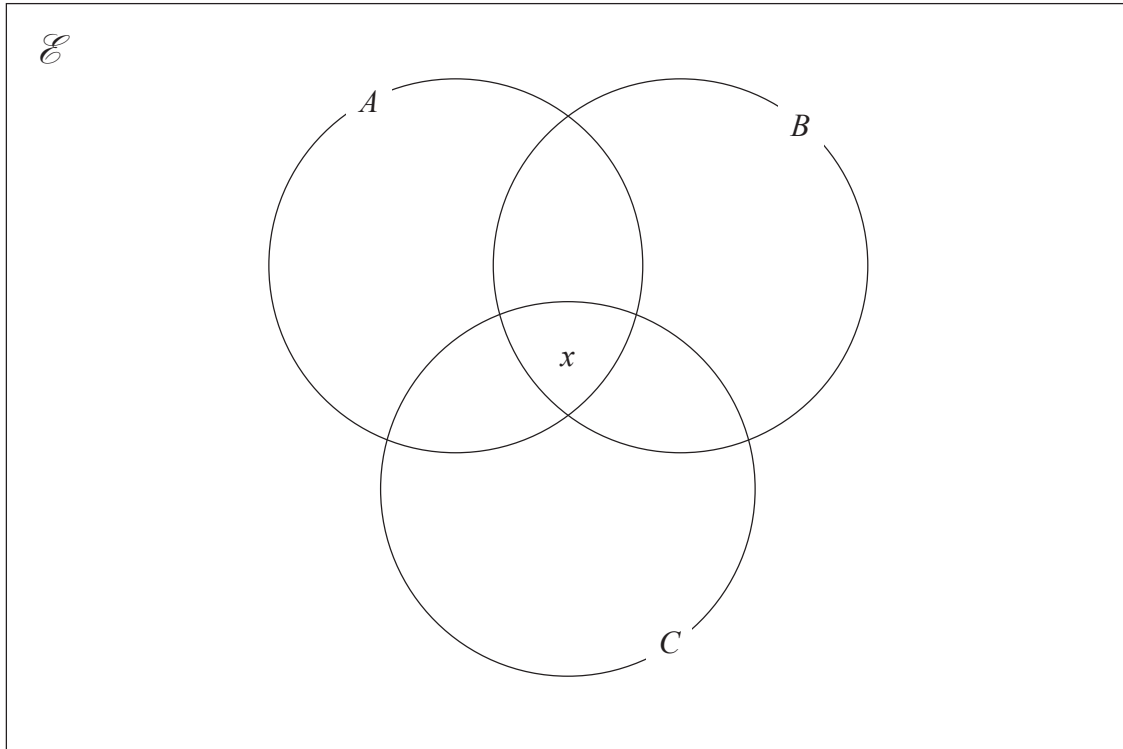

In the Venn diagram,  $n(A \cap B \cap C) = x$

It is given that sets  $\mathcal{E}$ ,  $A$ ,  $B$  and  $C$  are such that

$$n(\mathcal{E}) = 60$$

$$n([A \cup B \cup C]') = 4$$

$$n(A \cap B) = 8$$

$$n(B \cap C) = 7$$

$$n(A \cap C) = 13$$

$$n(A) = 37 - x$$

$$n(B) = 28 - x$$

$$n(C) = 29 - x$$

- (a) Using this information, complete the Venn diagram to show the number of elements in each appropriate subset.

(3)

- (b) (i) Using your Venn diagram, write down an equation in  $x$ .

- (ii) Hence find the value of  $x$ .

(2)

.....

.....

.....

.....



**Question 3 continued**

DO NOT WRITE IN THIS AREA

DO NOT WRITE IN THIS AREA

DO NOT WRITE IN THIS AREA

Handwriting practice area with horizontal dotted lines.

**(Total for Question 3 is 5 marks)**



- 4 The equation of a curve,  $C$ , is  $y = f(x)$  where  $f(x) = ax^2 + b$  for all values of  $x$ , and  $a$  and  $b$  are constants.

Given that  $C$  passes through the point with coordinates  $(1, -1)$

- (a) write down an equation in  $a$  and  $b$ .

(1)

Given also that  $C$  passes through the point with coordinates  $(3, 23)$

- (b) write down a second equation in  $a$  and  $b$ .

(1)

- (c) Solve your two equations to find the value of  $a$  and the value of  $b$ .

(3)

- (d) Using your values of  $a$  and  $b$ , write down the range of the function  $f$ .

(2)

DO NOT WRITE IN THIS AREA

DO NOT WRITE IN THIS AREA

DO NOT WRITE IN THIS AREA





**Question 4 continued**

DO NOT WRITE IN THIS AREA

DO NOT WRITE IN THIS AREA

DO NOT WRITE IN THIS AREA

Area with horizontal dotted lines for writing.

**(Total for Question 4 is 7 marks)**



5 A policeman uses a detection device to measure the speeds, in km/h, of vehicles passing a certain point on a road. The table below gives information about the speed recorded for each of 100 vehicles.

Speed ( $x$ km/h)	Number of vehicles
$0 < x \leq 20$	5
$20 < x \leq 40$	25
$40 < x \leq 50$	33
$50 < x \leq 60$	22
$60 < x \leq 90$	15

(a) Calculate an estimate for the mean speed of the 100 vehicles. (4)

The speed limit for vehicles at this point on the road is 50km/h. One of these 100 vehicles is chosen at random.

(b) Find the probability that the speed recorded for this vehicle is greater than the speed limit. (2)

.....

.....

.....

.....

.....

.....

.....

.....

.....

.....

.....

.....

.....

.....

.....

.....

.....

.....

.....

.....

.....

.....

.....

.....

DO NOT WRITE IN THIS AREA

DO NOT WRITE IN THIS AREA

DO NOT WRITE IN THIS AREA



**Question 5 continued**

(c) On the grid below complete the histogram to represent the information in the table.  
One bar has been drawn for you.

(4)

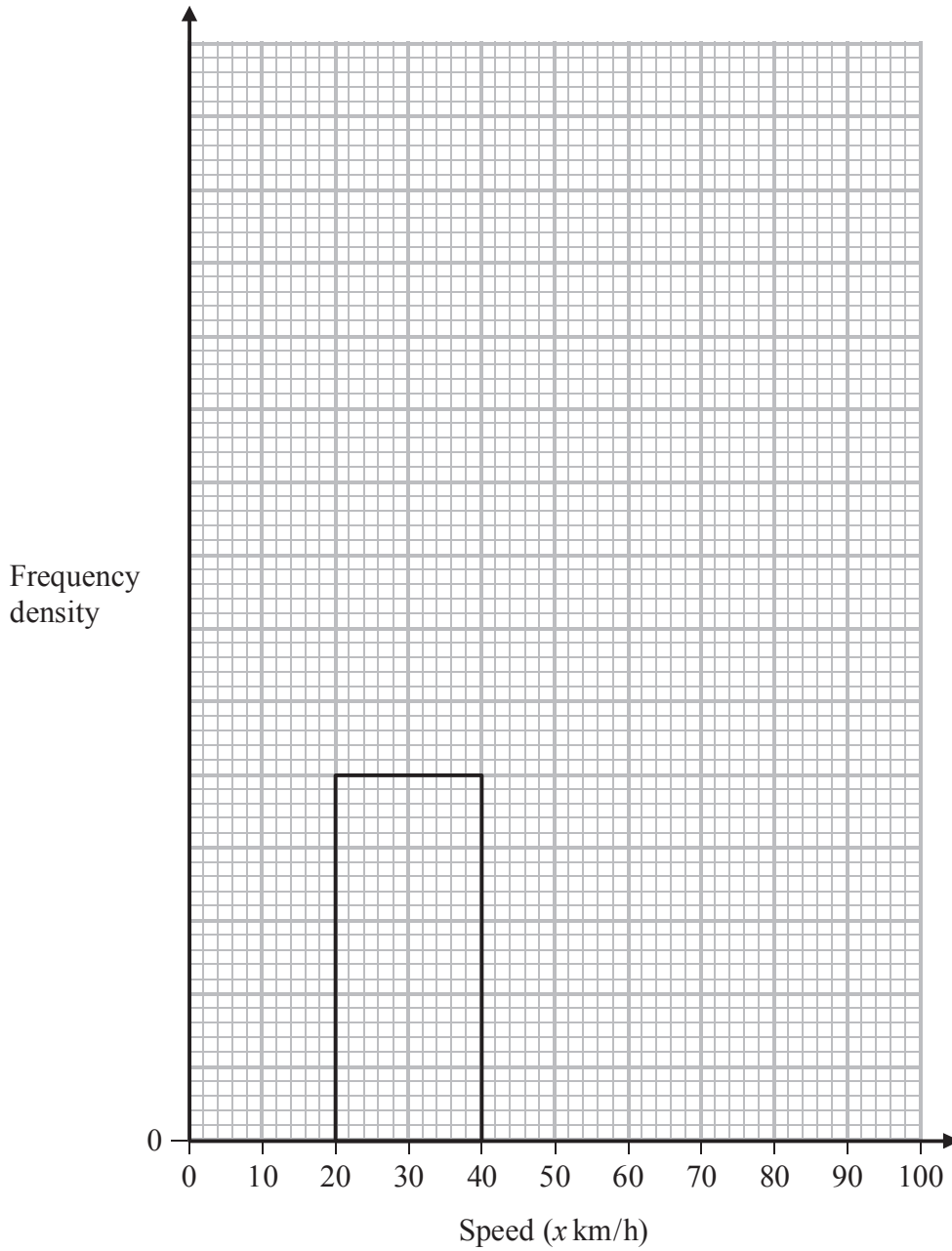

DO NOT WRITE IN THIS AREA

DO NOT WRITE IN THIS AREA

DO NOT WRITE IN THIS AREA



**Question 5 continued**

Handwriting practice area with 20 horizontal dotted lines.

DO NOT WRITE IN THIS AREA

DO NOT WRITE IN THIS AREA

DO NOT WRITE IN THIS AREA

**(Total for Question 5 is 10 marks)**



DO NOT WRITE IN THIS AREA

DO NOT WRITE IN THIS AREA

DO NOT WRITE IN THIS AREA

6 Simplify fully  $\frac{x^2 + 3x - 28}{(x + 3)^2 - 16}$

Handwriting practice area with horizontal dotted lines.

(Total for Question 6 is 5 marks)



7

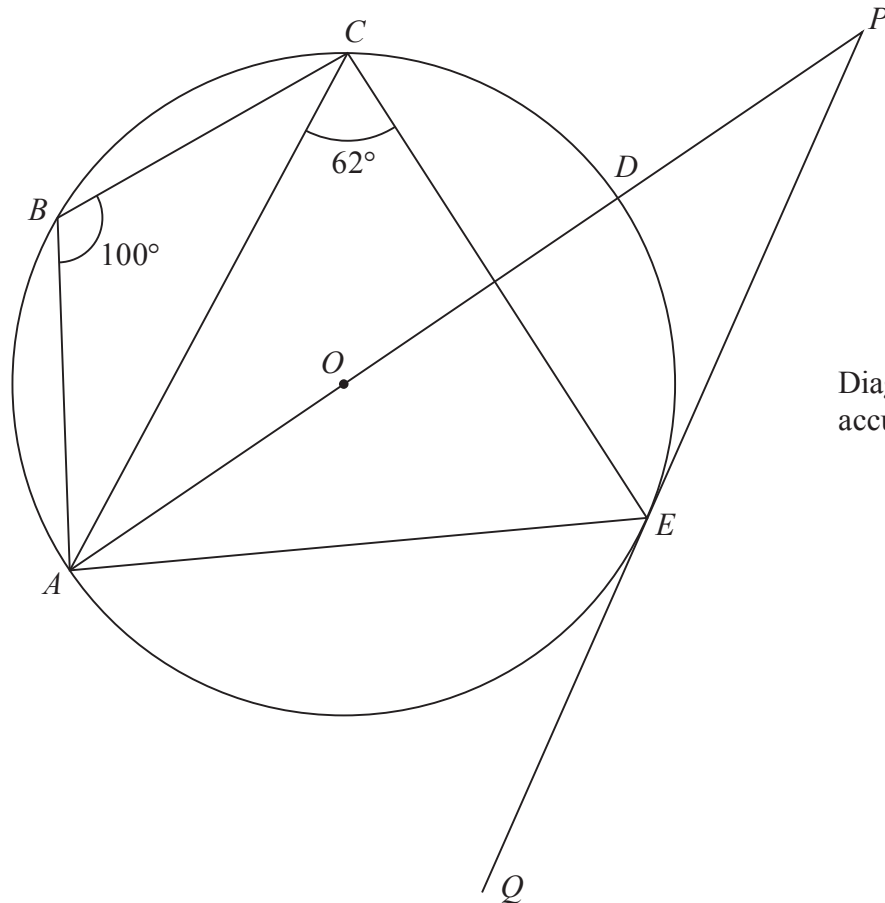

Diagram NOT accurately drawn

Figure 1

In Figure 1,  $ABCDE$  is a circle with centre  $O$  and with diameter  $AD$ .  
 $ADP$  and  $QEP$  are straight lines so that  $QEP$  is the tangent to the circle at the point  $E$ .  
 $\angle ABC = 100^\circ$  and  $\angle ACE = 62^\circ$

- (a) Giving reasons, find the size, in degrees, of
  - (i)  $\angle AEC$ ,
  - (ii)  $\angle AEQ$ .(4)
  
- (b) Giving reasons, show that  $\angle OAE = 28^\circ$  (4)
  
- (c) Hence find the size, in degrees, of  $\angle EPA$ . (2)

.....

.....

.....

.....

.....

DO NOT WRITE IN THIS AREA

DO NOT WRITE IN THIS AREA

DO NOT WRITE IN THIS AREA



**Question 7 continued**

DO NOT WRITE IN THIS AREA

DO NOT WRITE IN THIS AREA

DO NOT WRITE IN THIS AREA

Handwriting practice area with 25 horizontal dotted lines.



P 4 5 9 1 8 A 0 1 5 3 6

**Question 7 continued**

Handwriting practice area with 20 horizontal dotted lines.

DO NOT WRITE IN THIS AREA

DO NOT WRITE IN THIS AREA

DO NOT WRITE IN THIS AREA





**Question 7 continued**

DO NOT WRITE IN THIS AREA

DO NOT WRITE IN THIS AREA

DO NOT WRITE IN THIS AREA

Handwriting practice area with horizontal dotted lines.

**(Total for Question 7 is 10 marks)**



P 4 5 9 1 8 A 0 1 7 3 6

- 8 (a) Expand and simplify  $(5x + 192)(x - 80)$  (2)

The manager of a golf shop bought  $x$  identical golf balls at a total cost of \$480 to sell during a tournament.

- (b) Write down an expression in terms of  $x$  for the price, in \$, that the manager paid for one golf ball. (1)

The selling price of a golf ball was such that the profit made when the golf ball was sold is \$2.50

- (c) Find, as a single fraction, an expression in terms of  $x$  for the selling price, in \$, of one golf ball. (2)

At the end of the tournament, 16 of the golf balls had **not** been sold and the total selling price of the golf balls sold was \$544

- (d) Using all the information given, write down an equation in  $x$ . (1)

- (e) Show that your equation in part (d) simplifies to  $5x^2 - 208x - 15\,360 = 0$  (3)

- (f) Using part (a) or otherwise, find the number of golf balls bought by the manager of the golf shop for the tournament. (3)

.....

.....

.....

.....

.....

.....

.....

.....

.....

.....

.....

.....

.....

.....

.....

.....

.....

.....

.....

.....

.....

.....

DO NOT WRITE IN THIS AREA

DO NOT WRITE IN THIS AREA

DO NOT WRITE IN THIS AREA



**Question 8 continued**

DO NOT WRITE IN THIS AREA

DO NOT WRITE IN THIS AREA

DO NOT WRITE IN THIS AREA

Handwriting practice area with horizontal dotted lines.



P 4 5 9 1 8 A 0 1 9 3 6

**Question 8 continued**

Handwriting practice area with 20 horizontal dotted lines.

DO NOT WRITE IN THIS AREA

DO NOT WRITE IN THIS AREA

DO NOT WRITE IN THIS AREA



**Question 8 continued**

DO NOT WRITE IN THIS AREA

DO NOT WRITE IN THIS AREA

DO NOT WRITE IN THIS AREA

Handwriting practice area with horizontal dotted lines.

**(Total for Question 8 is 12 marks)**



9

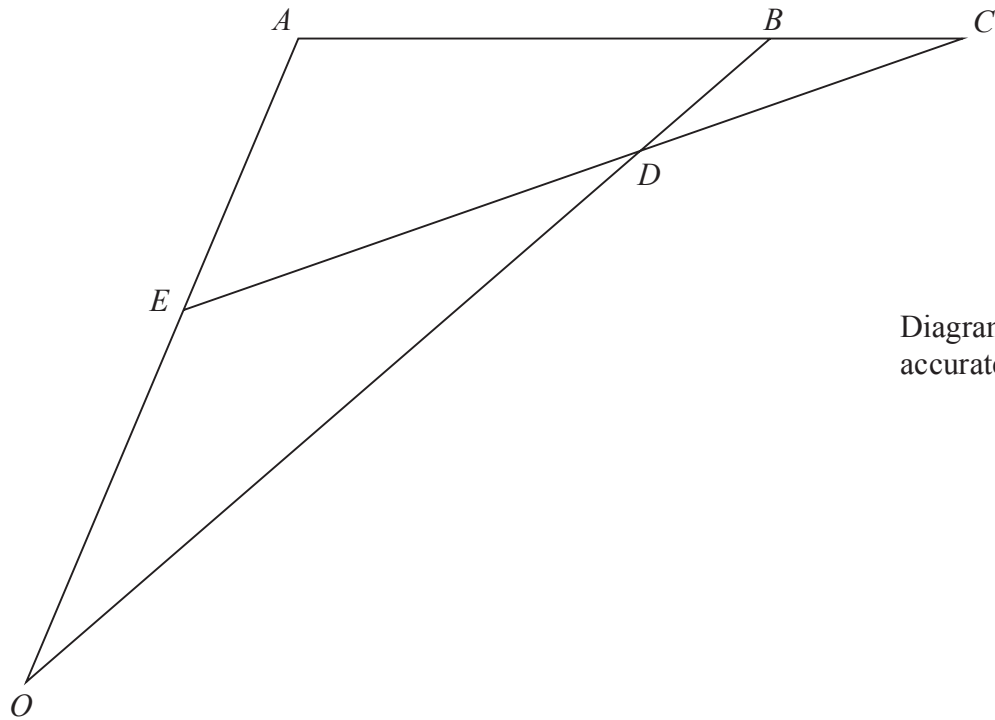

Diagram **NOT**  
accurately drawn

**Figure 2**

In Figure 2,  $OAB$  is a triangle such that  $\vec{OA} = 2\mathbf{a}$  and  $\vec{AB} = \mathbf{b}$ .  
The point  $E$  is the midpoint of  $OA$  and  $ABC$  is a straight line such that  $AB:AC = 4:5$   
The lines  $OB$  and  $CE$  intersect at the point  $D$ .

(a) Express in terms of  $\mathbf{a}$  and  $\mathbf{b}$  or  $\mathbf{a}$  or  $\mathbf{b}$

(i)  $\vec{OB}$       (ii)  $\vec{AC}$       (iii)  $\vec{EC}$

(3)

Given that  $\vec{OD} = \mu\vec{OB}$ , where  $\mu$  is a scalar,

(b) write down an expression for  $\vec{OD}$  in terms of  $\mu$ ,  $\mathbf{a}$  and  $\mathbf{b}$ .

(1)

Given also that  $\vec{ED} = \lambda\vec{EC}$ , where  $\lambda$  is a scalar,

(c) write down an expression for  $\vec{OD}$  in terms of  $\lambda$ ,  $\mathbf{a}$  and  $\mathbf{b}$ .

(1)

(d) Find the value of  $\lambda$  and the value of  $\mu$ .

(5)

The area of triangle  $OAD$  is 20 square units.

(e) Find the area of triangle  $ADB$ .

(2)

DO NOT WRITE IN THIS AREA

DO NOT WRITE IN THIS AREA

DO NOT WRITE IN THIS AREA



**Question 9 continued**

DO NOT WRITE IN THIS AREA

DO NOT WRITE IN THIS AREA

DO NOT WRITE IN THIS AREA

Handwriting practice area with horizontal dotted lines.



P 4 5 9 1 8 A 0 2 3 3 6

**Question 9 continued**

Handwriting practice area with 20 horizontal dotted lines.

DO NOT WRITE IN THIS AREA

DO NOT WRITE IN THIS AREA

DO NOT WRITE IN THIS AREA





**Question 9 continued**

DO NOT WRITE IN THIS AREA

DO NOT WRITE IN THIS AREA

DO NOT WRITE IN THIS AREA

Area with horizontal dotted lines for writing.

**(Total for Question 9 is 12 marks)**



P 4 5 9 1 8 A 0 2 5 3 6

- 10 (a) Show that the size of each interior angle of a regular pentagon is  $108^\circ$

(2)

Diagram **NOT**  
accurately drawn

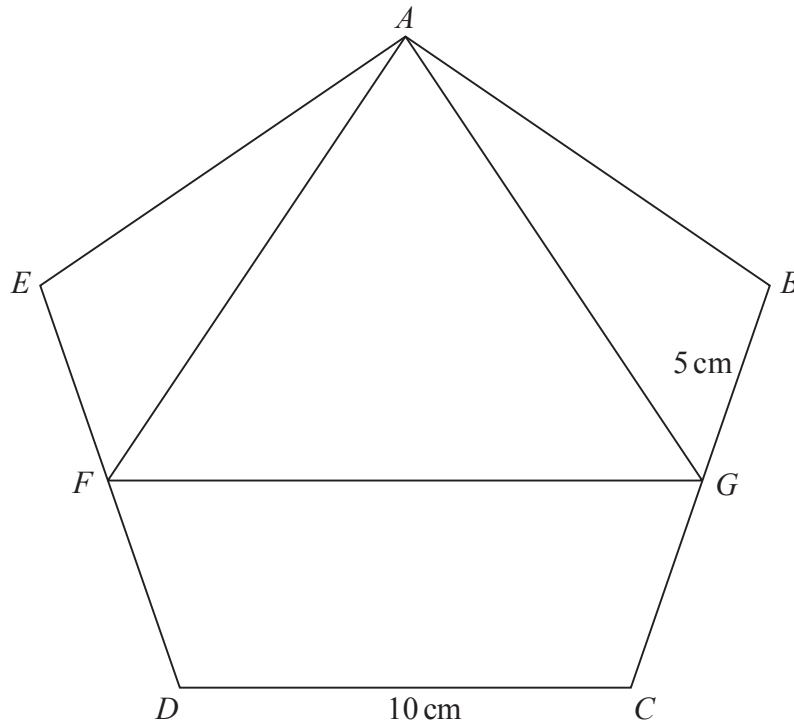

**Figure 3**

In Figure 3,  $ABCDE$  is a regular pentagon with sides of length 10 cm. The midpoints of  $ED$  and  $BC$  are  $F$  and  $G$  respectively.

Calculate, giving your answers to 3 significant figures,

- (b) the length, in cm, of  $AG$ ,

(3)

- (c) the size, in degrees, of  $\angle GAB$ ,

(3)

- (d) the area, in  $\text{cm}^2$ , of triangle  $GAF$ .

(3)

The area of the pentagon, to 4 significant figures, is  $172.0 \text{ cm}^2$

The region  $R$  consists of the points inside the pentagon but outside the triangle  $GAF$ .

- (e) Express the area of  $R$  as a percentage of the area of the pentagon. Give your answer to 3 significant figures.

(3)

$$\left( \begin{array}{l} \text{Sum of interior angles of polygon} = (2n - 4) \text{ right angles} \\ \text{Sine rule: } \frac{a}{\sin A} = \frac{b}{\sin B} = \frac{c}{\sin C} \\ \text{Cosine rule: } a^2 = b^2 + c^2 - 2bc \cos A \\ \text{Area of triangle} = \frac{1}{2} bc \sin A \end{array} \right)$$

DO NOT WRITE IN THIS AREA

DO NOT WRITE IN THIS AREA

DO NOT WRITE IN THIS AREA



**Question 10 continued**

DO NOT WRITE IN THIS AREA

DO NOT WRITE IN THIS AREA

DO NOT WRITE IN THIS AREA

Handwriting practice area with 28 horizontal dotted lines.



P 4 5 9 1 8 A 0 2 7 3 6

**Question 10 continued**

Handwriting practice area with 20 horizontal dotted lines.

DO NOT WRITE IN THIS AREA

DO NOT WRITE IN THIS AREA

DO NOT WRITE IN THIS AREA



**Question 10 continued**

DO NOT WRITE IN THIS AREA

DO NOT WRITE IN THIS AREA

DO NOT WRITE IN THIS AREA

Ruled area for writing the answer to Question 10.

**(Total for Question 10 is 14 marks)**



11

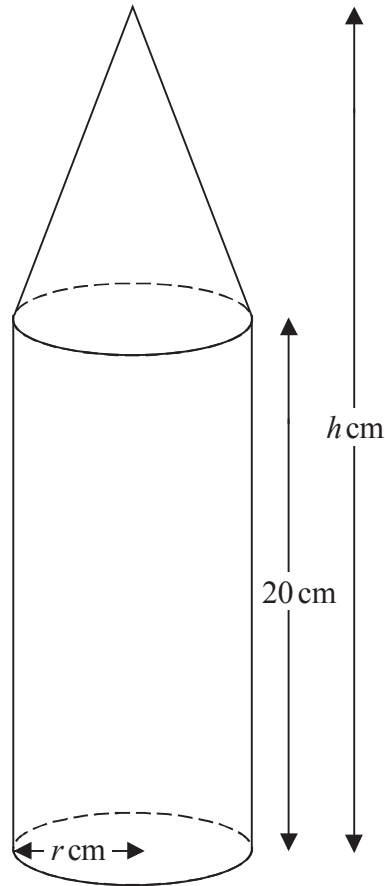

Diagram NOT  
accurately drawn

**Figure 4**

Figure 4 shows a firework which is made of a right circular cone on top of a right circular cylinder. The radius of the base of the cone is  $r$  cm and the radius of the cylinder is also  $r$  cm. The centre of the base of the cone coincides with the centre of the upper circular face of the cylinder.

The height of the cylinder is 20 cm, the height of the cone is  $H$  cm and the total height of the firework is  $h$  cm.

(a) Write down an expression for  $H$  in terms of  $h$ .

(1)

The volume of the cone is  $V$  cm<sup>3</sup>

(b) Write down a formula for  $V$  in terms of  $r$  and  $h$ .

(1)

$$\left( \begin{array}{l} \text{Area of a circle} = \pi r^2 \\ \text{Volume of a right circular cone} = \frac{1}{3} \pi r^2 h \end{array} \right)$$

DO NOT WRITE IN THIS AREA

DO NOT WRITE IN THIS AREA

DO NOT WRITE IN THIS AREA



**Question 11 continued**

For this firework,  $r + h = 32$

(c) Show that  $V = \pi(4r^2 - \frac{1}{3}r^3)$

(2)

DO NOT WRITE IN THIS AREA

DO NOT WRITE IN THIS AREA

DO NOT WRITE IN THIS AREA

Area with horizontal dotted lines for writing the solution.

**Question 11 continues on the next page**



P 4 5 9 1 8 A 0 3 1 3 6





Question 11 continued

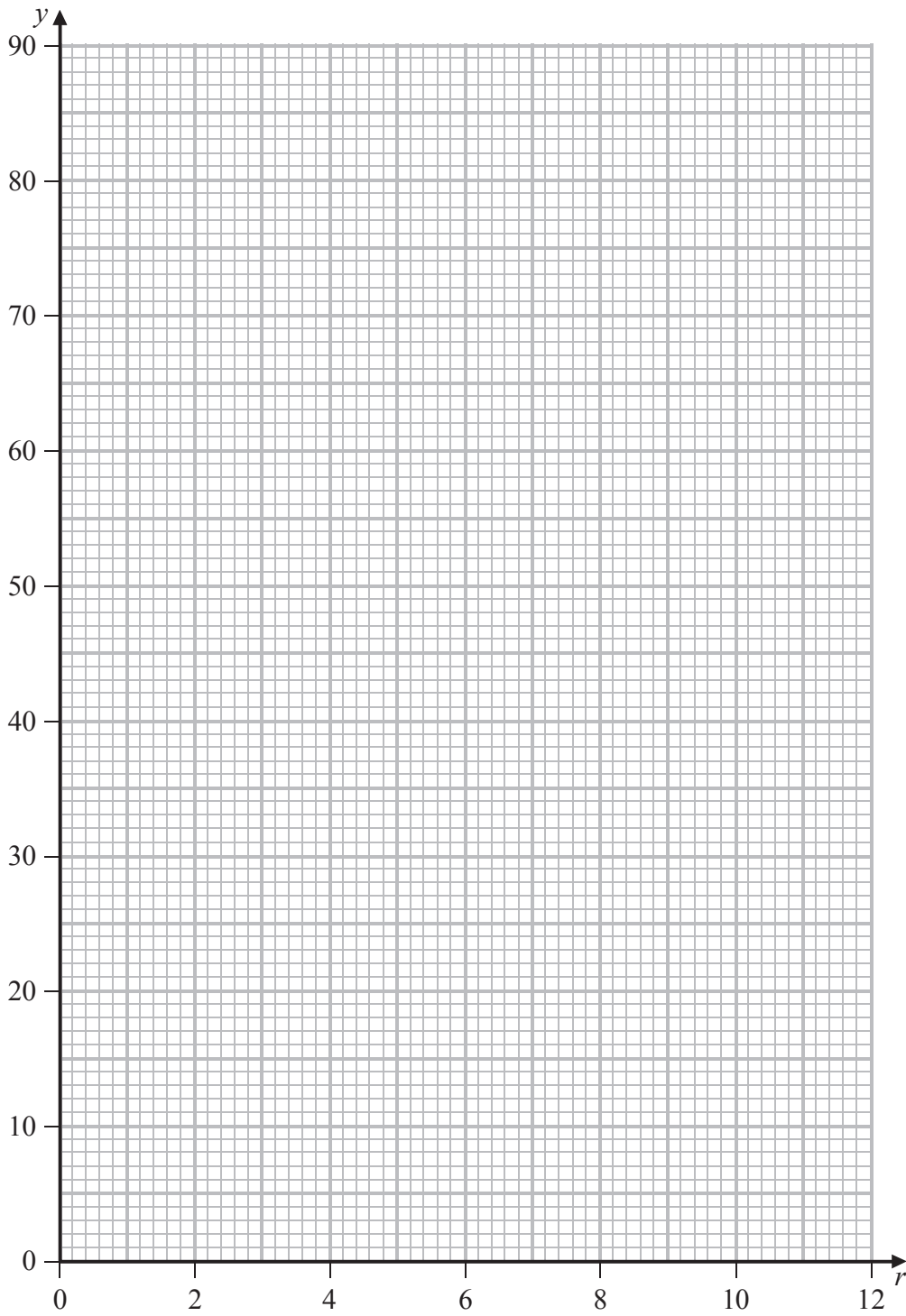

Turn over for a spare grid if you need to redraw your graph.

DO NOT WRITE IN THIS AREA

DO NOT WRITE IN THIS AREA

DO NOT WRITE IN THIS AREA



**Question 11 continued**

Handwriting practice area with 20 horizontal dotted lines.

DO NOT WRITE IN THIS AREA

DO NOT WRITE IN THIS AREA

DO NOT WRITE IN THIS AREA



Question 11 continued

Only use this grid if you need to redraw your graph.

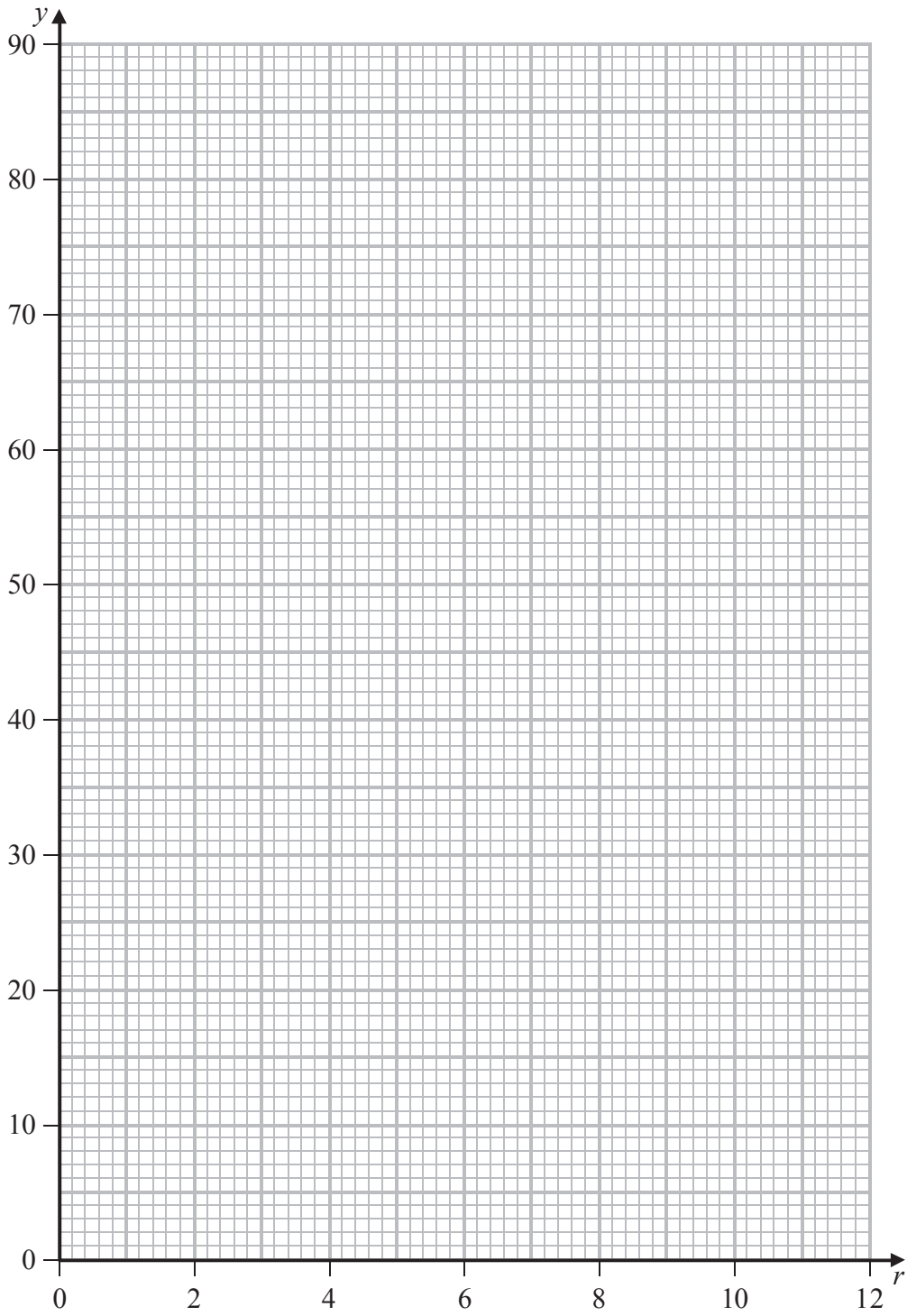

DO NOT WRITE IN THIS AREA

DO NOT WRITE IN THIS AREA

DO NOT WRITE IN THIS AREA



**Question 11 continued**

Area with horizontal dotted lines for writing.

DO NOT WRITE IN THIS AREA

DO NOT WRITE IN THIS AREA

DO NOT WRITE IN THIS AREA

**(Total for Question 11 is 16 marks)**

**TOTAL FOR PAPER IS 100 MARKS**

