

Please check the examination details below before entering your candidate information

Candidate surname				Other names							
Pearson Edexcel				Centre Number				Candidate Number			
International GCSE				<input type="text"/> <input type="text"/> <input type="text"/> <input type="text"/> <input type="text"/> <input type="text"/>				<input type="text"/> <input type="text"/> <input type="text"/> <input type="text"/> <input type="text"/> <input type="text"/>			
Thursday 4 June 2020											
Morning (Time: 2 hours 30 minutes)						Paper Reference 4MB1/02R					
Mathematics B											
Paper 2R											
You must have: Ruler graduated in centimetres and millimetres, protractor, pair of compasses, pen, HB pencil, eraser, calculator. Tracing paper may be used.										Total Marks	

Instructions

- Use **black** ink or ball-point pen.
- **Fill in the boxes** at the top of this page with your name, centre number and candidate number.
- Answer **all** questions.
- Answer the questions in the spaces provided
– *there may be more space than you need.*
- **Calculators may be used.**

Information

- The total mark for this paper is 100.
- The marks for **each** question are shown in brackets
– *use this as a guide as to how much time to spend on each question.*

Advice

- Read each question carefully before you start to answer it.
- Check your answers if you have time at the end.
- Without sufficient working, correct answers may be awarded no marks.

Turn over ►

P62019A

©2020 Pearson Education Ltd.

1/1/1/1/



Pearson

Answer all TWELVE questions.

Write your answers in the spaces provided.

You must write down all the stages in your working.

1 The manufacturer's price for a *Jinko* car is \$ x

Ben was given a 7% discount on the manufacturer's price when he bought a *Jinko*.
Ben paid \$23 622 when he bought his *Jinko*.

(a) Calculate the value of x . (2)

After a year Ben sold his *Jinko* for \$19 880

(b) Calculate the percentage loss, to 3 significant figures, on the price Ben paid for his *Jinko*. (2)

During the year that Ben owned the *Jinko*, he travelled d km in the car.
The average fuel consumption of the car was 10 km per litre.
The average cost of the fuel he used was \$1.40 per litre.
Other costs for the car in the year came to \$938

The cost per km, including the loss in value, of his *Jinko* to Ben during the year that he owned the car was \$0.40

(c) Calculate the value of d . (4)

.....

.....

.....

.....

.....

.....

.....

.....

.....

.....

.....

.....

.....

.....

.....

.....

.....

.....

.....

.....

.....

.....

.....

DO NOT WRITE IN THIS AREA

DO NOT WRITE IN THIS AREA

DO NOT WRITE IN THIS AREA



Question 1 continued

DO NOT WRITE IN THIS AREA

DO NOT WRITE IN THIS AREA

DO NOT WRITE IN THIS AREA

Handwriting practice area with 28 horizontal dotted lines.

(Total for Question 1 is 8 marks)



- 2 (a) Find the Highest Common Factor (HCF) of 75, 90 and 120

(2)

Bhu sets the alarm on her phone to sound at 09 10
Her alarm then sounds every 12 minutes.

Dax sets the alarm on his phone to sound at 09 30
His alarm then sounds every 8 minutes.

Bhu's alarm sounds at 09 10 and Dax's alarm sounds at 09 30

- (b) Find the first time after 09 30 that both alarms will sound at the same time.

(2)

DO NOT WRITE IN THIS AREA

DO NOT WRITE IN THIS AREA

DO NOT WRITE IN THIS AREA



Question 2 continued

DO NOT WRITE IN THIS AREA

DO NOT WRITE IN THIS AREA

DO NOT WRITE IN THIS AREA

Handwriting practice area with 28 horizontal dotted lines.

(Total for Question 2 is 4 marks)



3 (a) Solve the equation $3a + 6 = 4 - 5a$ (2)

(b) Solve the inequality $3p > 6p + 12$ (2)

An inequality, in w , is shown on a number line below.

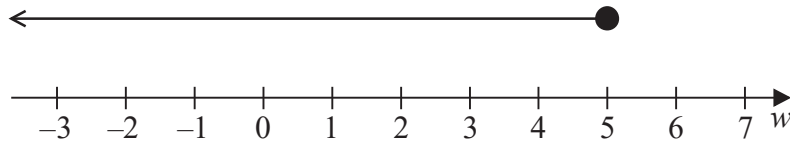

(c) Write down the inequality. (1)

(d) Write down the 3 inequalities that define the shaded region R in Figure 1

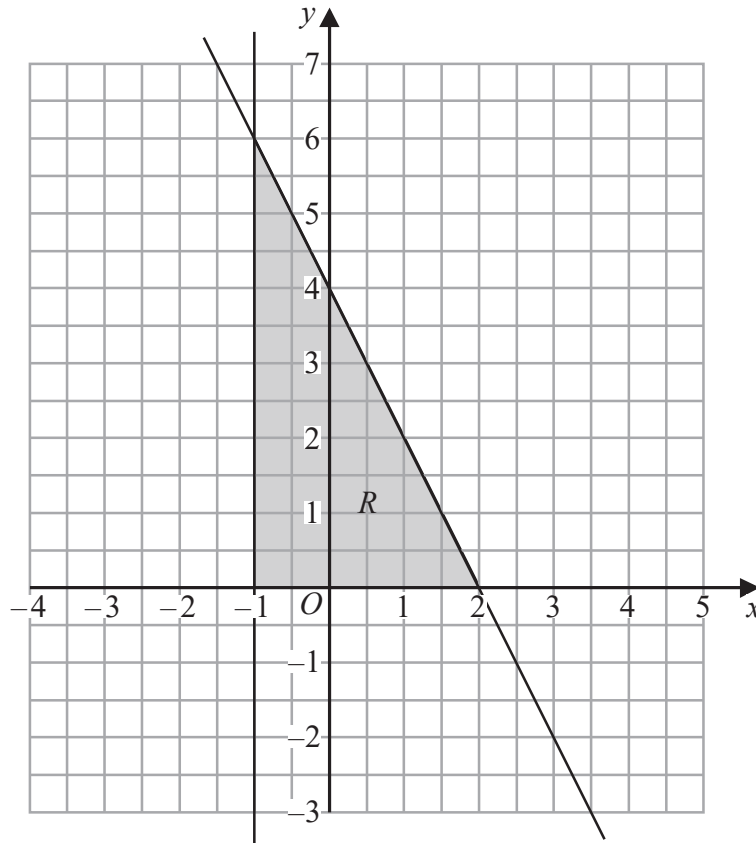

Figure 1

(3)

.....

.....

.....

.....

.....



DO NOT WRITE IN THIS AREA

DO NOT WRITE IN THIS AREA

DO NOT WRITE IN THIS AREA

Question 3 continued

DO NOT WRITE IN THIS AREA

DO NOT WRITE IN THIS AREA

DO NOT WRITE IN THIS AREA

Area with horizontal dotted lines for writing.

(Total for Question 3 is 8 marks)



- 4 A youth club has introduced three new activities

badminton (B), cookery (C) and drama (D).

Each of the 75 members of the youth club is asked to say in which of these activities they have participated.

Their answers showed that of the 75 members

all have participated in at least one of these activities

27 have participated in badminton and drama

31 have participated in badminton and cookery

23 have participated in cookery and drama

48 have participated in badminton

49 have participated in cookery

40 have participated in drama.

Let x be the number of members of the youth club who have participated in all three activities.

- (a) Using all this information, complete the Venn diagram opposite to show, in terms of x , the number of elements in each appropriate subset. (3)
- (b) Find the value of x . (2)
- (c) Find
- (i) $n(B \cap C')$
- (ii) $n\left(\left[(B \cup C) \cap D\right]'\right)$ (2)

One of the members of the youth club is picked at random.

Given that this member has participated in cooking,

- (d) find the probability that this member has not participated in any other activity. (2)

.....

.....

.....

.....

.....

.....

.....



Question 4 continued

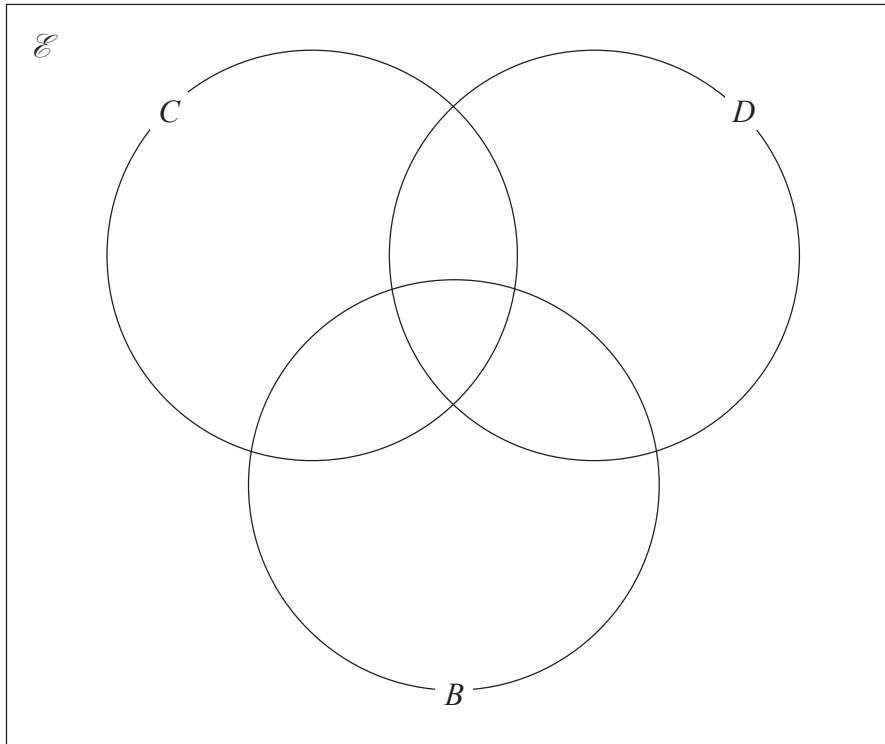

DO NOT WRITE IN THIS AREA

DO NOT WRITE IN THIS AREA

DO NOT WRITE IN THIS AREA

Area with horizontal dotted lines for writing.

Turn over for a spare Venn diagram if you need to redraw your diagram.



P 6 2 0 1 9 A 0 9 3 6

Question 4 continued

Only use this diagram if you need to redraw your Venn diagram.

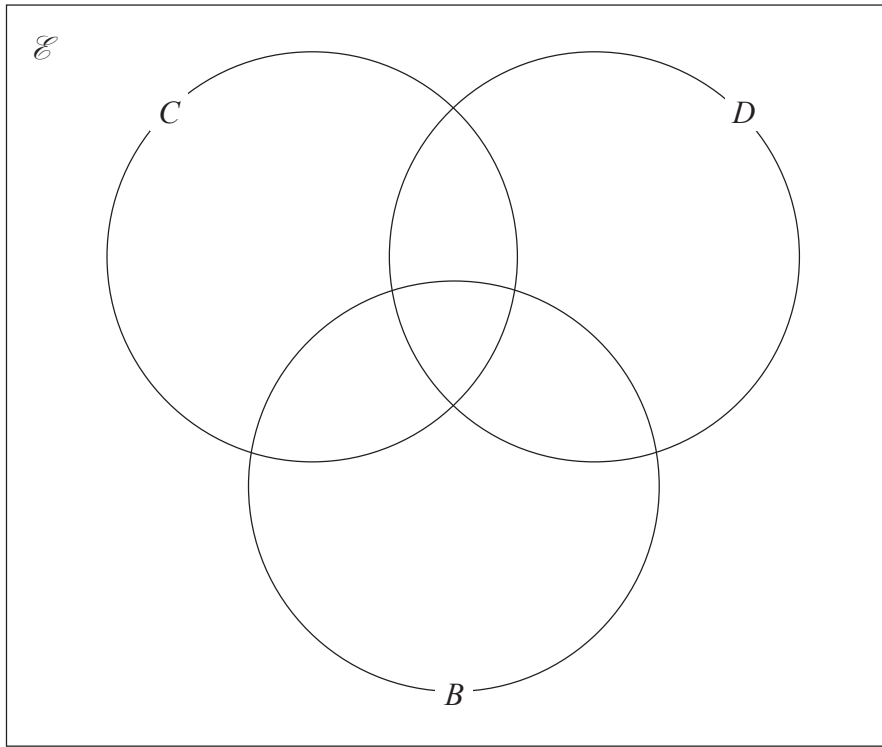

.....

.....

.....

.....

.....

.....

.....

.....

.....

.....

.....

.....

.....

.....

.....

.....

.....

.....

.....

.....

.....

.....

.....

.....

(Total for Question 4 is 9 marks)

DO NOT WRITE IN THIS AREA

DO NOT WRITE IN THIS AREA

DO NOT WRITE IN THIS AREA



5 (a) Factorise $x^2 + 5x - 6$

(2)

(b) Express as a single fraction in its simplest form

$$\frac{x+3}{5} - \frac{2x-2}{4}$$

(3)

DO NOT WRITE IN THIS AREA

DO NOT WRITE IN THIS AREA

DO NOT WRITE IN THIS AREA

(Total for Question 5 is 5 marks)



P 6 2 0 1 9 A 0 1 1 3 6

6 The points with coordinates (1, 1), (3, 1) and (4, 3) are the vertices of triangle *A*.

- (a) On the grid opposite, draw and label triangle *A*. (1)

Triangle *B* is the image of triangle *A* under the transformation with matrix **M** where

$$\mathbf{M} = \begin{pmatrix} -2 & 0 \\ 0 & 2 \end{pmatrix}$$

- (b) On the grid opposite, draw and label triangle *B*. (3)

Triangle *C* is the image of triangle *B* under a reflection in the line with equation $y = 0$

- (c) On the grid opposite, draw and label triangle *C*. (1)

Triangle *A* is transformed to triangle *C* under the transformation with matrix **N**.

- (d) Find matrix **N**. (2)

Triangle *D* is the image of triangle *C* under a rotation through 180° about the point (1, 1)

- (e) On the grid opposite, draw and label triangle *D*. (2)

- (f) Describe fully the **single** transformation that maps triangle *D* onto triangle *A*. (3)

.....

.....

.....

.....

.....

.....

.....

.....

.....

.....

.....

.....

.....

.....

.....

.....

.....

.....

.....

.....

.....

.....

.....

DO NOT WRITE IN THIS AREA

DO NOT WRITE IN THIS AREA

DO NOT WRITE IN THIS AREA



Question 6 continued

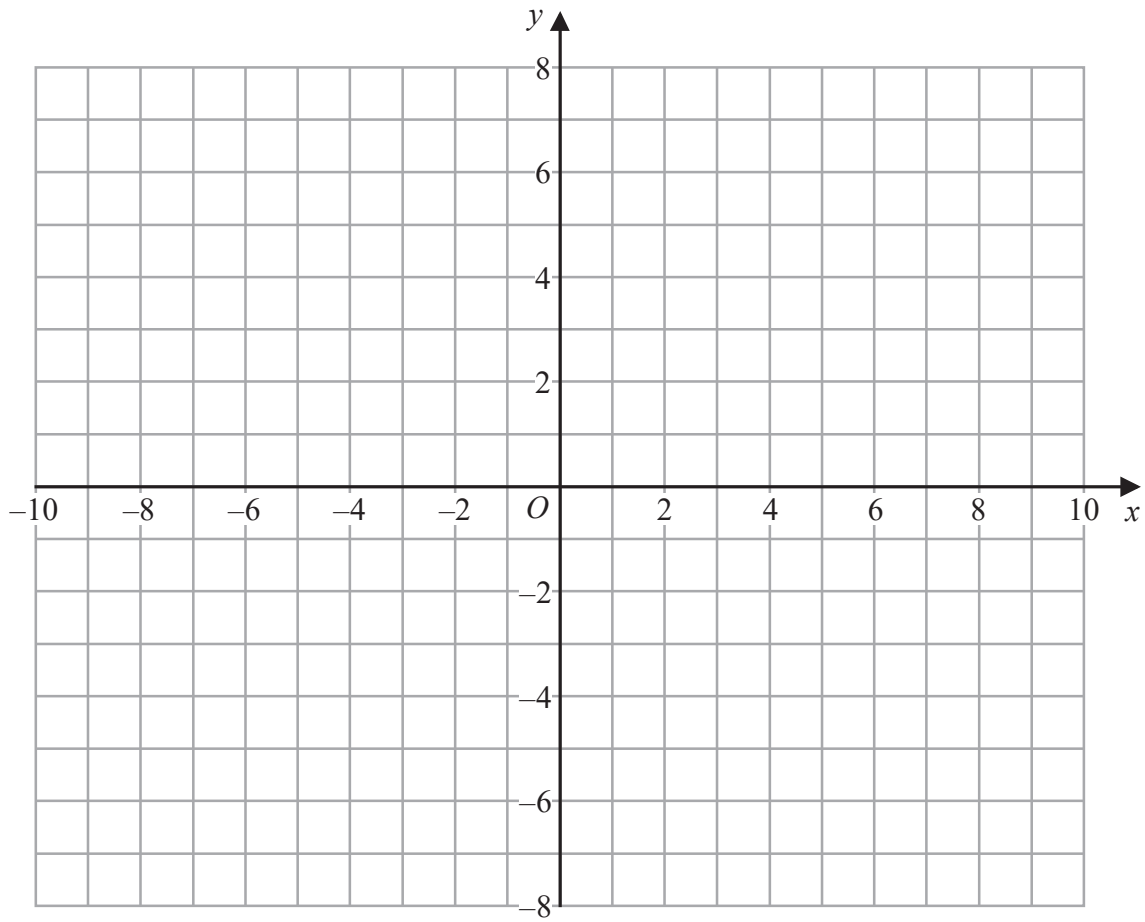

DO NOT WRITE IN THIS AREA

DO NOT WRITE IN THIS AREA

DO NOT WRITE IN THIS AREA

.....

.....

.....

.....

.....

.....

.....

.....

.....

.....

.....

.....

.....

.....

.....

.....

.....

.....

.....

.....

.....

.....

Turn over for a spare copy of the grid if you need to redraw your triangles.



P 6 2 0 1 9 A 0 1 3 3 6

Question 6 continued

Handwriting practice area with 20 horizontal dotted lines.

DO NOT WRITE IN THIS AREA

DO NOT WRITE IN THIS AREA

DO NOT WRITE IN THIS AREA



Question 6 continued

Only use this grid if you need to redraw your triangles.

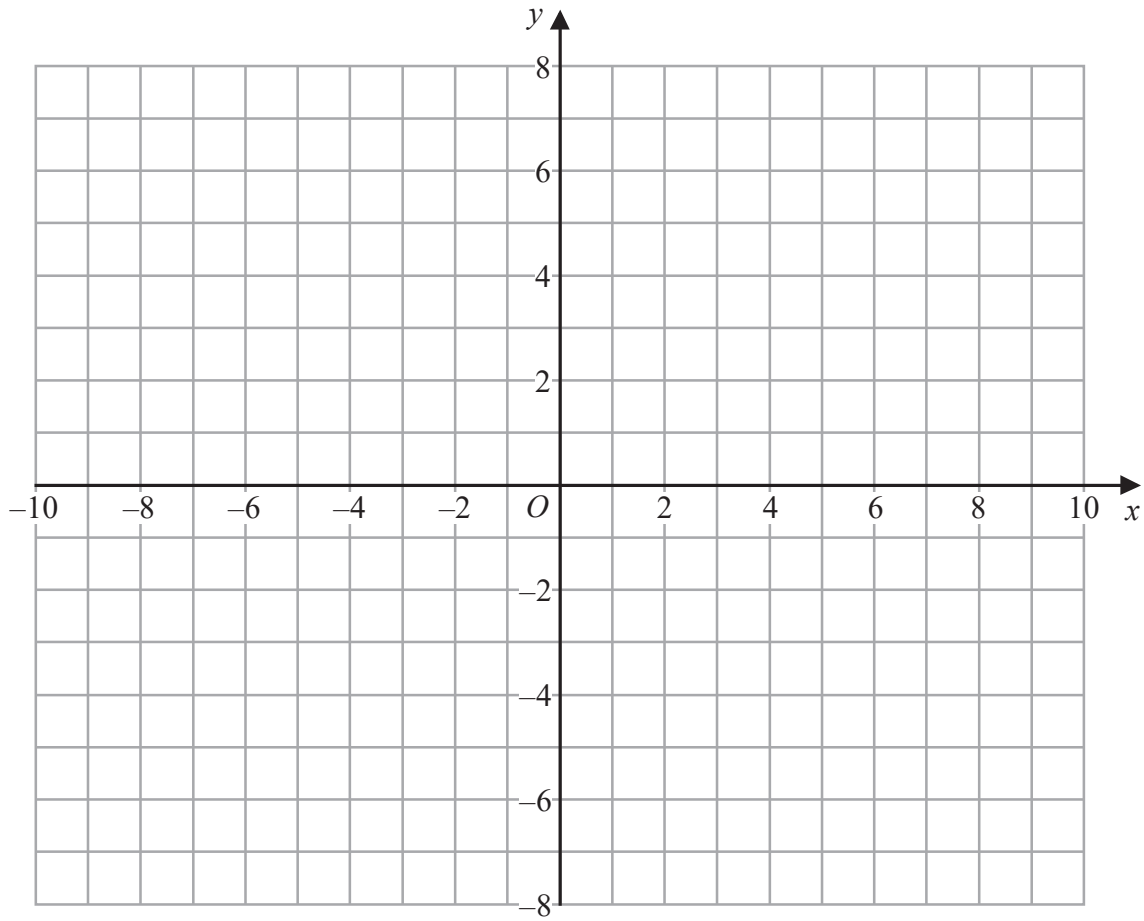

DO NOT WRITE IN THIS AREA

DO NOT WRITE IN THIS AREA

DO NOT WRITE IN THIS AREA

.....

.....

.....

.....

.....

.....

.....

.....

.....

.....

.....

.....

(Total for Question 6 is 12 marks)



P 6 2 0 1 9 A 0 1 5 3 6

- 7 The table gives information about the length of time, in seconds, that each of 28 birds spent on Ali's bird table on Monday.

Length of time (t seconds)	Frequency
$0 < t \leq 5$	10
$5 < t \leq 8$	8
$8 < t \leq 10$	5
$10 < t \leq 15$	3
$15 < t \leq 30$	2
$t > 30$	0

- (a) Find the class interval that contains the median length of time that the birds spent on the bird table on Monday. (1)
- (b) Calculate an estimate, in seconds to one decimal place, for the mean length of time that the birds spent on the bird table on Monday. (4)

The incomplete histogram below gives some information about the length of time, in seconds, that each of 35 birds spent on Ali's bird table on Tuesday.

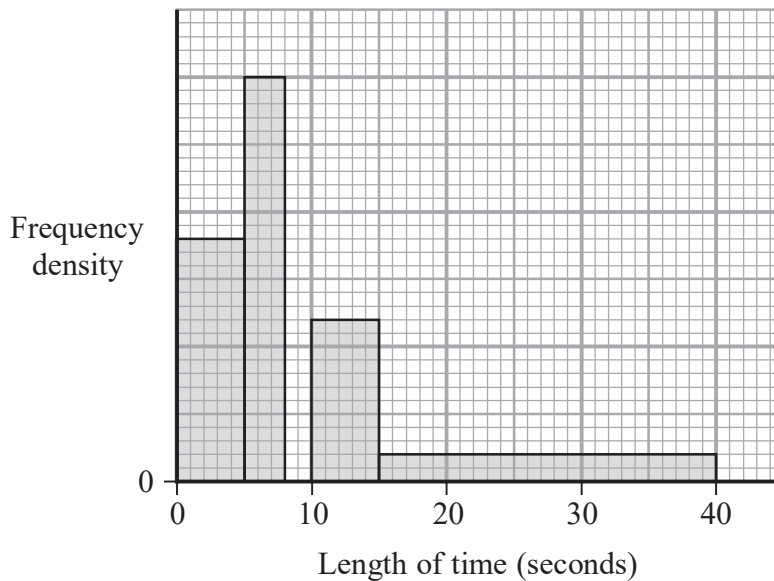

On Tuesday

- 9 of the birds spent between 5 seconds and 8 seconds on the bird table
- 6 of the birds spent between 8 seconds and 10 seconds on the bird table
- no bird spent longer than 40 seconds on the bird table.

- (c) Use this information to complete the histogram. (1)
- (d) Find the proportion of birds on Tuesday that spent longer than 15 seconds on the bird table. (1)

Turn over for a spare copy of the histogram if you need to redraw your bar.



Question 7 continued

DO NOT WRITE IN THIS AREA

DO NOT WRITE IN THIS AREA

DO NOT WRITE IN THIS AREA

Area with horizontal dotted lines for writing.



P 6 2 0 1 9 A 0 1 7 3 6

Question 7 continued

Handwriting practice area with 20 horizontal dotted lines.

DO NOT WRITE IN THIS AREA

DO NOT WRITE IN THIS AREA

DO NOT WRITE IN THIS AREA



DO NOT WRITE IN THIS AREA

DO NOT WRITE IN THIS AREA

DO NOT WRITE IN THIS AREA

Question 7 continued

Only use this histogram if you need to redraw your bar.

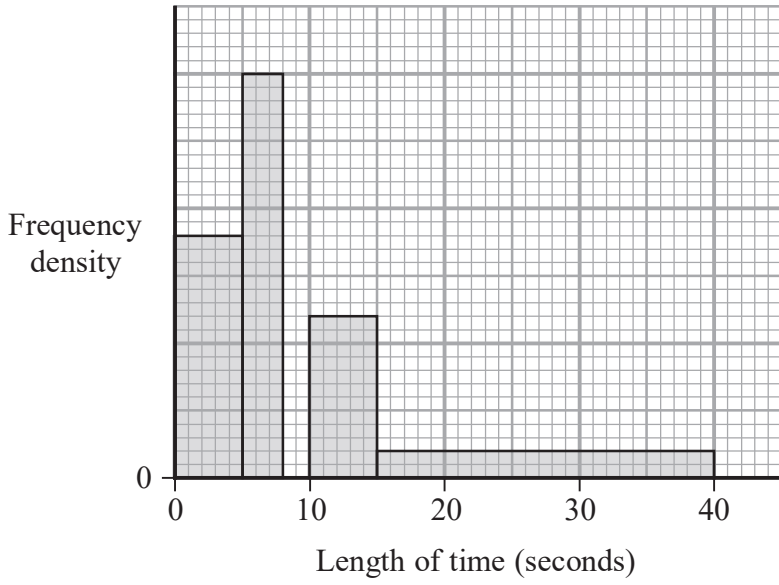

.....

.....

.....

.....

.....

.....

.....

.....

.....

.....

.....

.....

.....

.....

.....

.....

.....

.....

.....

.....

.....

.....

.....

.....

(Total for Question 7 is 7 marks)



P 6 2 0 1 9 A 0 1 9 3 6

8 Jenny ran a road race.

The distance Jenny ran was 5 km, to the nearest 20 m.

Jenny's time for the race was 34 minutes, to the nearest minute.

Colin ran a different road race.

The distance Colin ran was 10 km, to the nearest 200 m.

Colin's time for the race was 1 hour 8 minutes, to the nearest minute.

Colin's average speed for his race is greater than Jenny's average speed for her race.

Calculate the upper bound for the difference, in km/h, between Colin's average speed and Jenny's average speed.

Show your working clearly.

(5)

.....

.....

.....

.....

.....

.....

.....

.....

.....

.....

.....

.....

.....

.....

.....

.....

.....

.....

.....

.....

.....

.....

.....

.....

DO NOT WRITE IN THIS AREA

DO NOT WRITE IN THIS AREA

DO NOT WRITE IN THIS AREA



Question 8 continued

DO NOT WRITE IN THIS AREA

DO NOT WRITE IN THIS AREA

DO NOT WRITE IN THIS AREA

Area with horizontal dotted lines for writing.

(Total for Question 8 is 5 marks)



- 9 Figure 2 shows two shapes *A* and *B*.
All the lengths are in metres.

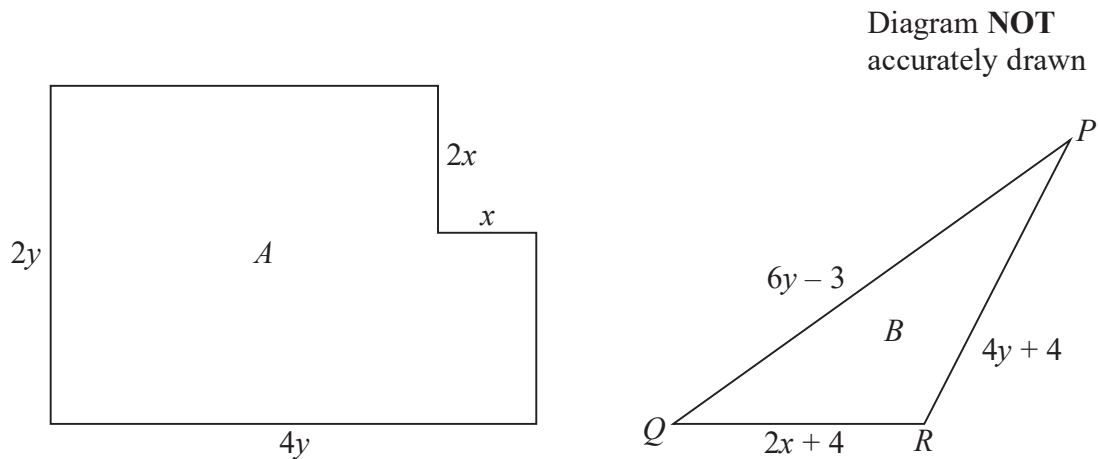

Figure 2

The corners of shape *A* are all right angles.
The area of shape *A* is 400 m^2
Shape *B* is triangle *PQR*.

The perimeter of shape *A* is equal to the perimeter of shape *B*.

- (a) Show that $4y^2 - x^2 = 200$ and that $2y = 2x + 5$ (3)
- (b) Find the value of *x* and the value of *y*.
Show clear algebraic working. (5)

.....

.....

.....

.....

.....

.....

.....

.....

.....

.....

.....

.....

.....

DO NOT WRITE IN THIS AREA

DO NOT WRITE IN THIS AREA

DO NOT WRITE IN THIS AREA



Question 9 continued

DO NOT WRITE IN THIS AREA

DO NOT WRITE IN THIS AREA

DO NOT WRITE IN THIS AREA

Area with horizontal dotted lines for writing.



P 6 2 0 1 9 A 0 2 3 3 6

Question 9 continued

Handwriting practice area with 20 horizontal dotted lines.

DO NOT WRITE IN THIS AREA

DO NOT WRITE IN THIS AREA

DO NOT WRITE IN THIS AREA



Question 9 continued

DO NOT WRITE IN THIS AREA

DO NOT WRITE IN THIS AREA

DO NOT WRITE IN THIS AREA

Area with horizontal dotted lines for writing.

(Total for Question 9 is 8 marks)



P 6 2 0 1 9 A 0 2 5 3 6

10

$$f(x) = 3x^3 - 7x^2 + 5x - 1$$

(a) Use the factor theorem to show that $(3x - 1)$ is a factor of $f(x)$. (2)

(b) Hence solve the equation $f(x) = 0$
Show clear algebraic working. (3)

The curve C has equation $y = f(x)$

(c) Find the exact coordinates of the turning points on C . (5)

The curve C crosses the y -axis at the point P .

(d) (i) Find the gradient of C at P . (1)

(ii) Hence find an equation of the tangent to C at P . (2)

.....
.....
.....
.....
.....
.....
.....
.....
.....
.....
.....
.....
.....
.....
.....
.....
.....
.....
.....
.....
.....
.....
.....

DO NOT WRITE IN THIS AREA

DO NOT WRITE IN THIS AREA

DO NOT WRITE IN THIS AREA



Question 10 continued

DO NOT WRITE IN THIS AREA

DO NOT WRITE IN THIS AREA

DO NOT WRITE IN THIS AREA

Area with horizontal dotted lines for writing.



P 6 2 0 1 9 A 0 2 7 3 6

Question 10 continued

Handwriting practice area with 20 horizontal dotted lines.

DO NOT WRITE IN THIS AREA

DO NOT WRITE IN THIS AREA

DO NOT WRITE IN THIS AREA



Question 10 continued

DO NOT WRITE IN THIS AREA

DO NOT WRITE IN THIS AREA

DO NOT WRITE IN THIS AREA

Area with horizontal dotted lines for writing.

(Total for Question 10 is 13 marks)



11

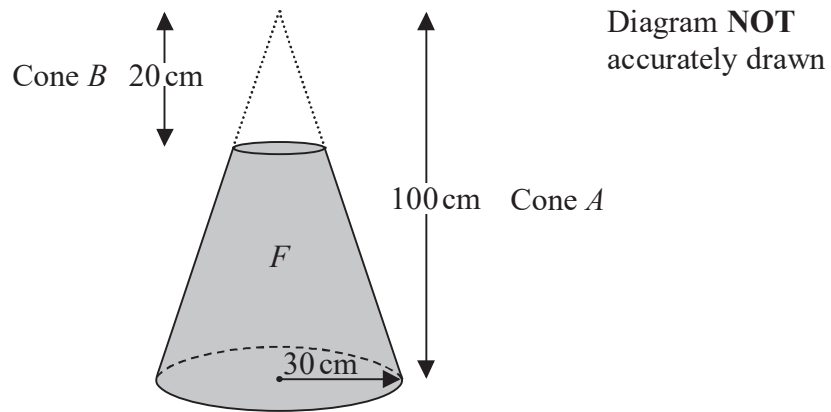

Figure 3

A right circular cone, A , has height 100 cm and base radius 30 cm.
The shaded solid, F , is formed by removing the right circular cone, B , of height 20 cm from the top of A , as shown in Figure 3

The volume of F is $k\pi \text{ cm}^3$ where k is an integer.

(a) Find the value of k .

(3)

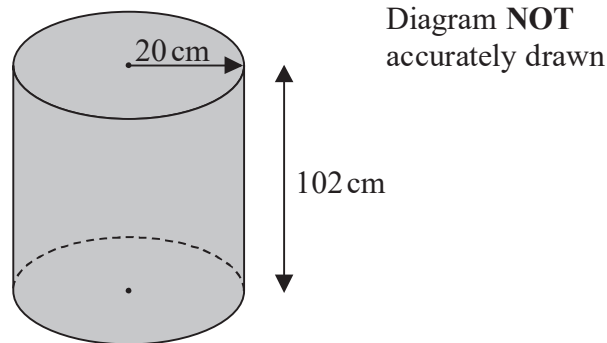

Figure 4

Figure 4 shows a solid circular cylinder.
The cylinder has a radius of 20 cm, a height of 102 cm and a volume of $V \text{ cm}^3$

(b) Calculate the value of V .
Give your answer in terms of π .

(1)

$$\left[\begin{array}{l} \text{Volume of a cylinder} = \pi r^2 h \\ \text{Volume of a cone} = \frac{1}{3} \pi r^2 h \end{array} \right]$$



Question 11 continued

DO NOT WRITE IN THIS AREA

DO NOT WRITE IN THIS AREA

DO NOT WRITE IN THIS AREA

Area with horizontal dotted lines for writing.

Question 11 continues on the next page.



P 6 2 0 1 9 A 0 3 1 3 6

Question 11 continued

Figure 5 below shows a door stop made from a hollow hemisphere and a hollow right circular cone.

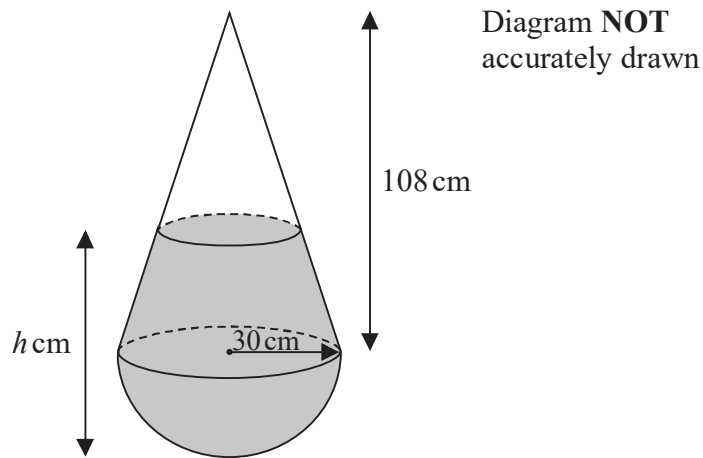

Figure 5

The radius of the base of the cone and the radius of the hemisphere are both 30 cm.
The centre of the base of the cone coincides with the centre of the hemisphere.
The height of the cone is 108 cm.

The door stop rests on horizontal ground with the cone on top of the hemisphere and the axis of symmetry of the door stop vertical.

The door stop contains sand to a height of h cm.

Given that the volume of sand in the door stop is V cm³, where V cm³ is the volume of the cylinder in Figure 4

(c) calculate the value of h .

(6)

.....

.....

.....

.....

.....

.....

.....

.....

.....

.....

$$\left[\text{Volume of a sphere} = \frac{4}{3}\pi r^3 \right]$$



Question 11 continued

DO NOT WRITE IN THIS AREA

DO NOT WRITE IN THIS AREA

DO NOT WRITE IN THIS AREA

Area with horizontal dotted lines for writing.

(Total for Question 11 is 10 marks)



P 6 2 0 1 9 A 0 3 3 3 6

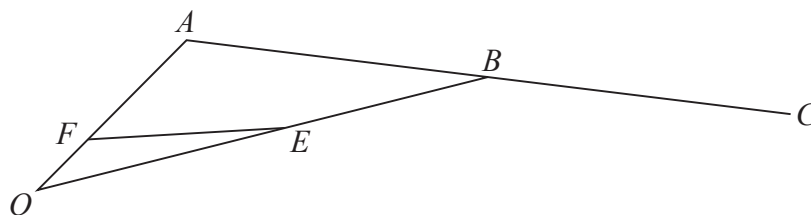

Diagram NOT accurately drawn

Figure 6

Figure 6 shows triangle OAB .

The point E lies on OB such that $OE : OB = 1 : 2$

The point F lies on OA such that $\vec{OF} = \frac{1}{5} \vec{OA}$

Given that $\vec{OA} = \mathbf{a}$ and $\vec{OB} = \mathbf{b}$

- (a) find \vec{FE} in terms of \mathbf{a} and \mathbf{b} (2)

The point C is such that ABC is a straight line and $AB = BC$.

- (b) Show that F, E and C are not collinear. (4)

Given that ABG and FEG are straight lines,

- (c) find \vec{OG} in terms of \mathbf{a} and \mathbf{b} (5)

.....

.....

.....

.....

.....

.....

.....

.....

.....

.....

.....

.....

.....

.....

.....

.....

.....

.....

.....

.....

DO NOT WRITE IN THIS AREA

DO NOT WRITE IN THIS AREA

DO NOT WRITE IN THIS AREA



Question 12 continued

DO NOT WRITE IN THIS AREA

DO NOT WRITE IN THIS AREA

DO NOT WRITE IN THIS AREA

Area with horizontal dotted lines for writing.



P 6 2 0 1 9 A 0 3 5 3 6

Question 12 continued

Dotted lines for writing.

DO NOT WRITE IN THIS AREA

DO NOT WRITE IN THIS AREA

DO NOT WRITE IN THIS AREA

(Total for Question 12 is 11 marks)

TOTAL FOR PAPER IS 100 MARKS

